

# PowerPod

## Three-phase All-in-One Energy Storage System User Manual

---

WH-TIA 502 Series  
WH-TIA 602 Series  
WH-TIA 802 Series  
WH-TIA 103 Series  
WH-TIA 123 Series  
WH-TIA 133 Series

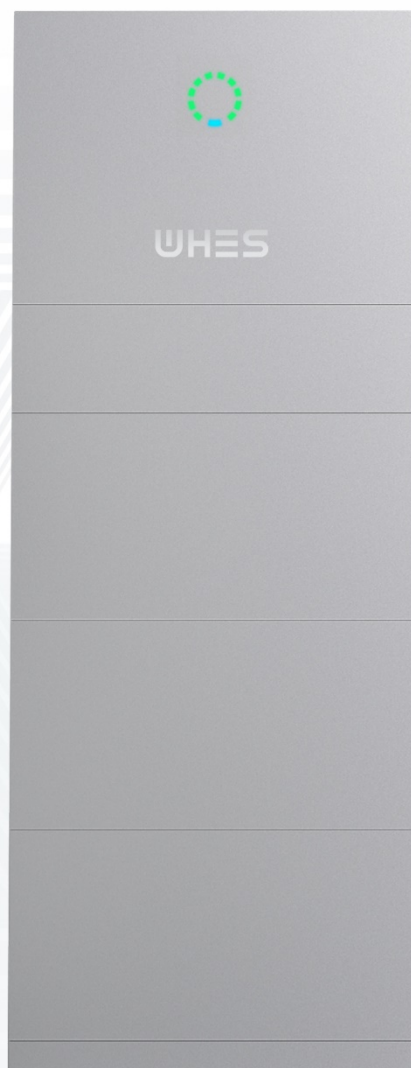

# CONTENTS

<b>COPYRIGHT STATEMENT</b> .....	<b>1</b>
<b>1 NOTE ON THIS MANUAL</b> .....	<b>1</b>
1.1 Applicable Model.....	1
1.2 Target Group.....	1
1.3 Symbols in the Manual.....	1
1.4 Version.....	2
<b>2 SAFETY</b> .....	<b>4</b>
2.1 Important Safety Instructions.....	4
2.2 Safety Warning.....	4
2.3 Limitation of Liability.....	5
<b>3 INTRODUCTION</b> .....	<b>6</b>
3.1 Product Overview.....	6
3.2 Features.....	6
3.3 Application Scenarios.....	7
3.4 Dimensions.....	8
3.5 Indicator Status and Communication Port.....	9
3.6 Product identity definition.....	12
3.7 Technical Data.....	13
<b>4 INSTALLATION</b> .....	<b>16</b>
4.1 Packing List.....	16
4.2 Installation Location and Environment.....	17
4.2.1 General.....	17
4.2.2 Location Restrictions.....	18
4.2.3 Barriers to Habitable Rooms.....	18
4.2.4 Choosing an Installation Location.....	20
4.3 Installation Steps.....	21
4.4 Cable Connections.....	28
4.4.1 General.....	28
4.4.2 Connect the Inverter Box and Battery Box.....	28
4.4.3 System Connection Diagrams.....	36
<b>5 System Operation</b> .....	<b>37</b>
5.1 Turning on the system.....	37
5.2 Turning off the system.....	38
<b>6 ECACTUS CONFIGURATION &amp; WI-FI RELOAD</b> .....	<b>39</b>
6.1 Preparations.....	39
6.2 Wi-Fi Reset & Restore.....	40
6.3 Change Password & Delete Account.....	42
<b>7 EMS CONFIGURATIONS</b> .....	<b>44</b>

<b>8</b>	<b>TROUBLESHOOTING.....</b>	<b>45</b>
<b>9</b>	<b>EMERGENCIES.....</b>	<b>49</b>
9.1	Emergency Procedures.....	49
9.2	First Aid Procedures.....	49
9.3	Firefighting Measures.....	49
<b>10</b>	<b>Remarks .....</b>	<b>50</b>
10.1	Recycle and Disposal.....	50
10.2	Maintenance.....	50
10.3	Declaration of conformity.....	50

## **COPYRIGHT STATEMENT**

The copyright of this manual belongs to Jiangsu Weiheng Intelligent Technology Co., Ltd. Hereinafter referred to as WHES. Any corporation or individual should not plagiarize, partially or fully copy (including software, etc.), and no reproduction or distribution of it in any form or by any means. All rights reserved. Please properly store the manual and strictly follow all safety and operating instructions provided. Please do not operate the system before reading through this manual.

## **NOTICE**

The information in this user manual is subject to change due to product updates or other reasons. This guide cannot replace the product labels or the safety precautions in the user manual unless otherwise specified. All descriptions here are for guidance only.

# 1 NOTE ON THIS MANUAL

## 1.1 Applicable Model

This manual is valid for PowerPod three-phase all-in-one energy storage system which includes hybrid inverter WH-TIA series and battery WH-BXC series. It describes the information, installation, electrical connection, commissioning, and maintenance and troubleshooting of the product. Please read it carefully before operating.

## 1.2 Target Group

This manual applies to qualified electricians. The qualified electricians have to be familiar with the product, local standards, and electric systems. The tasks described in this manual should only be performed by qualified electricians. End users can also use this manual to understand the product and functions.

## 1.3 Symbols in the Manual

Important instructions contained in this manual should be followed during installation, operation and maintenance.

### **⚠ DANGER**

Indicates a hazard with a high level of risk that, if not avoided, will result in death or serious injury.

### **⚠ WARNING**

Indicates a hazard with a medium level of risk that, if not avoided, could result in death or serious injury.

### **⚠ CAUTION**

Indicates a hazard with a low level of risk that, if not avoided, could result in minor or moderate injury.

### **NOTICE**

Indicates a situation that, if not avoided, could result in equipment or property damage.

The follow types of warning and safety symbols appearing on the product are described below:



Potential risks exist.

Wear proper PPE before any operations.



Danger to life due to electric shock

The product operates at high voltages. All work on the product must be carried out by qualified persons only.



Risk of burns due to hot surfaces

The product can get hot during operation. Avoid contact during operation. Allow the product to cool down sufficiently before carrying out any work.



Heavy objects. Life with care.



Keep the battery from open fire or ignition sources.



Recyclable product components.



This side up. The package must always be transported, handled, and stored upright, with the arrows pointing upwards.



Do not stack more than five identical packages on top of each other.



WEEE designation

Do not dispose of the product together with the household waste but in accordance with the locally applicable disposal regulations for electronic waste.



Handle the package/product with care, and do not tip it over or throw it.



Observe the documentation

Observe all documentation supplied with the product.



Keep dry

The package/product must be protected from excessive humidity and stored covered.



CE marking

The product complies with the requirements of the applicable EU directives.

## 1.4 Version

The latest document contains all the updates made in previous versions.

### V1.0 2024-08-10:

- First Issue.

### V1.1 2025-04-25:

- Company brand information change.

### V1.2 2025-07-01

- Added description about installation location near the sea in Section 4.2.4.

## 2 SAFETY

### 2.1 Important Safety Instructions

This manual contains important instructions for PowerPod three-phase all-in-one energy storage system that should be followed during installation and maintenance.

The system is designed and tested strictly complies with related safety rules. Please read and follow all the safety instructions and cautions before any operations. Improper operation might cause personal injury or property damage as the BESS is electrical equipment.

### 2.2 Safety Warning

- The product must only be installed or operated by qualified electricians in compliance with local grid authority or company standards, wiring rules, and requirements.
- Disconnect all batteries and AC power sources from the product for at least 5 minutes before connecting any wires or conducting any electrical work to ensure the product is completely isolated and to avoid electric shocks.
- The surface of the product may exceed temperatures of 60 °C during operation. Please make sure it has cooled down before touching it, and make sure that the product is out of the reach of children.
- The product must be used and operated as described in this user manual, or safety features may not work as intended, and the warranty for the product will be voided.
- The warranty will be voided if you open the product cover or change any component without WHES's authorization.
- Care must be taken to protect the product from static damage. The WEIHENG Limited Warranty does not cover any damage caused by static.
- Neutral continuity is NOT maintained internally and must be achieved through external connections, as shown in the system connection diagram for Australia on page 36 section 4.4.3.
- The product features a built-in residual current monitoring unit (RCMU). Only use type B external residual current device (RCD) rated for a tripping current of 30 mA or higher.
- This product features active anti-islanding protection, and inverter frequency is shifted away from nominal conditions in the absence of a reference frequency (frequency shift).

- This product is a multimode inverter designed to be used in unconditioned outdoor shaded environments. The maximum operating ambient temperature is 55°C.
- An error message will be sent to the ECOS app in the event of a ground fault, and the status indicator on the product will turn red.

### **2.3 Limitation of Liability**

WHES assumes no direct or indirect liability for any product damage or property losses caused by the following.

- Product modifications, design changes, or parts replaced without WHES's authorization;
- Modifications or attempted repairs or removal of serial numbers or seals by non-WHES technicians;
- System designs and installations not in compliance with standards or regulations;
- Damage caused during transportation (including scratched paint caused by the product rubbing against the packaging during shipping). Any claims for damage during shipping should be made directly with the shipping or insurance company as the container/packaging is unloaded and damage is identified;
- Failure to follow any/all of the user manual, installation guide, or maintenance guidelines;
- Improper use or misuse of the device;
- Insufficient ventilation around the device;
- Product maintenance not done to acceptable standards;
- Force majeure (including severe or stormy weather, lightning, and fires).

## 3 INTRODUCTION

### 3.1 Product Overview

The product is included a hybrid inverter with battery and it can be applied in DC coupled system, AC coupled system, and off-grid (with generator) system. It can store and release the energy from solar or grid according to the requirements of built-in EMS. With backup function, it can supply power to critical loads in case of power outage.

This manual applies to the listed parts of the product below:

#### Inverter Part

Product code	Model	Name	Description
PowerPod Three Phase Hybrid Inverter Module	WH-TIA502	5kW Three Phase Hybrid Inverter	Used in combination with PV panels and Agave-TH BAT for photovoltaic storage systems
	WH-TIA602	6kW Three Phase Hybrid Inverter	
	WH-TIA802	8kW Three Phase Hybrid Inverter	
	WH-TIA103	10kW Three Phase Hybrid Inverter	
	WH-TIA123	12kW Three Phase Hybrid Inverter	
	WH-TIA133	13kW Three Phase Hybrid Inverter	

#### Battery Part

Product code	Model	Name	Description
PowerPod High Voltage Box	HBC571-I	High Voltage Box	Used for data transmission and instruction delivery between battery and inverter
PowerPod Battery Module	WH- BXC4992	4.992kWh Battery Box	Store and release energy

### 3.2 Features

- Max 16/26A DC input current per string, compatible with 210 PV modules. Up to 110% three-phase unbalanced output.
- Cable free connection, saving 75% installation time between modules.
- IP65, indoor or outdoor application. <25dB, no noise pollution.
- Maximum of 5 units in parallel, covering a capacity range up to 149.76kWh.

- 4-layer protection design. Long life cell, The most stringent safety testing-UL 9540A.
- VPP, EV and Diesel Generator ready. Remote updates & self-diagnosis.

### 3.3 Application Scenarios

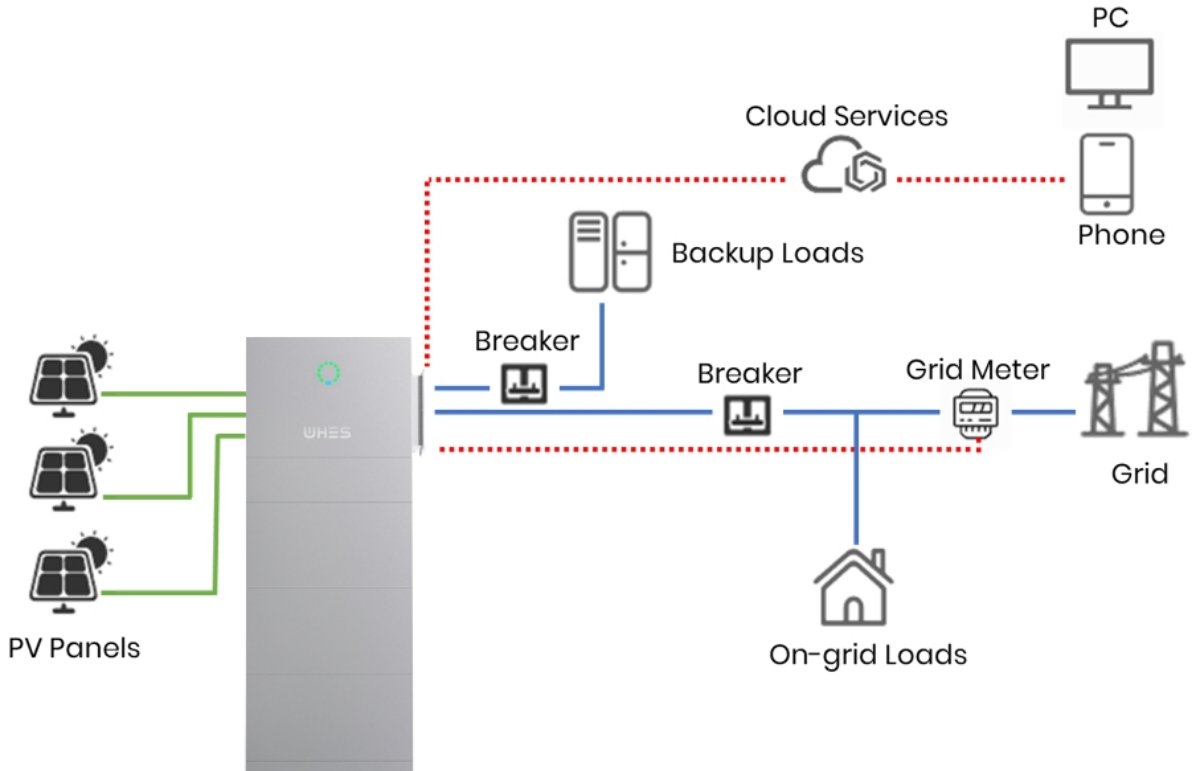

\*For AC coupled system, additional PV meter is required to monitor the existed inverter.

### 3.4 Dimensions

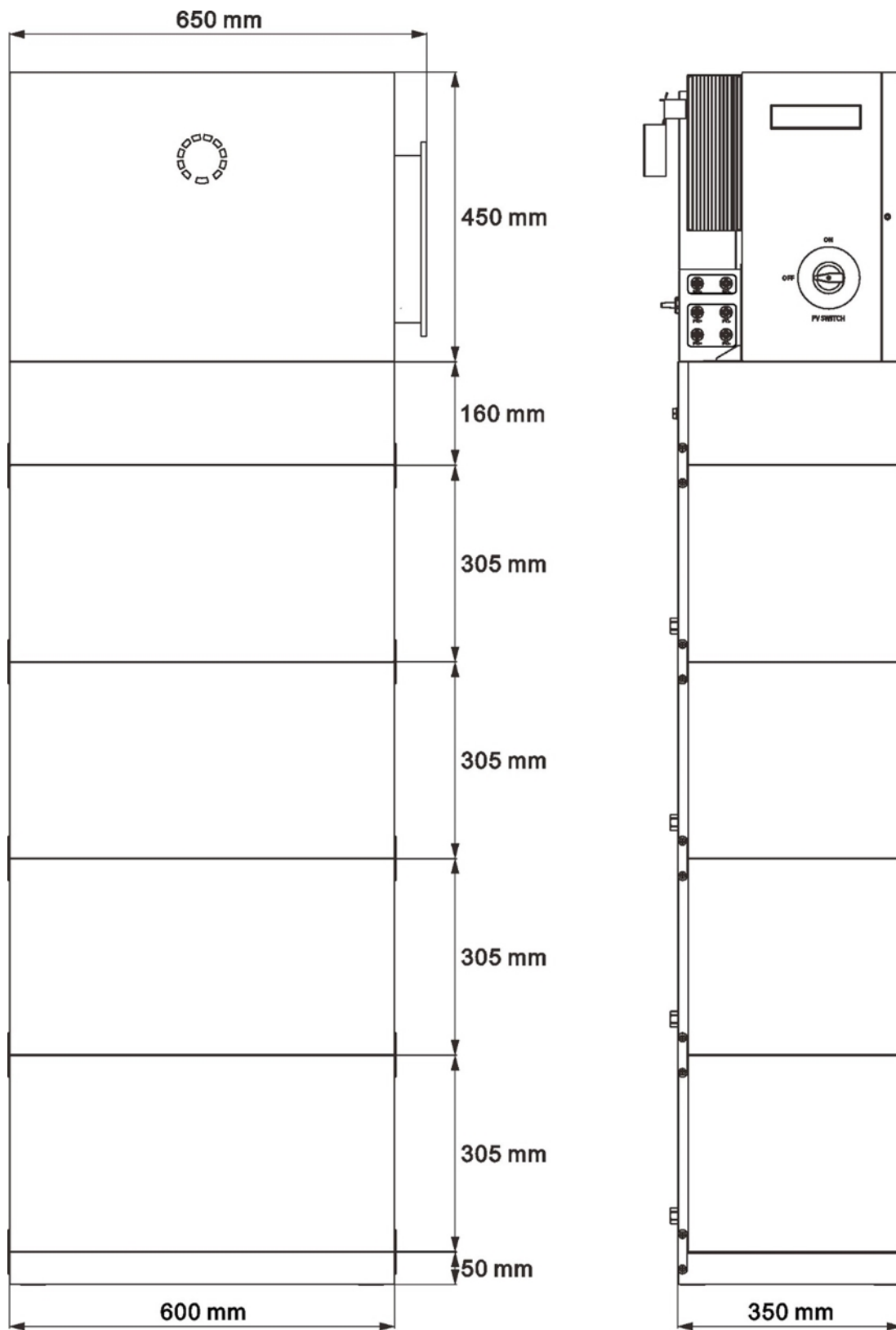

### 3.5 Indicator Status and Communication Port

- System appearance

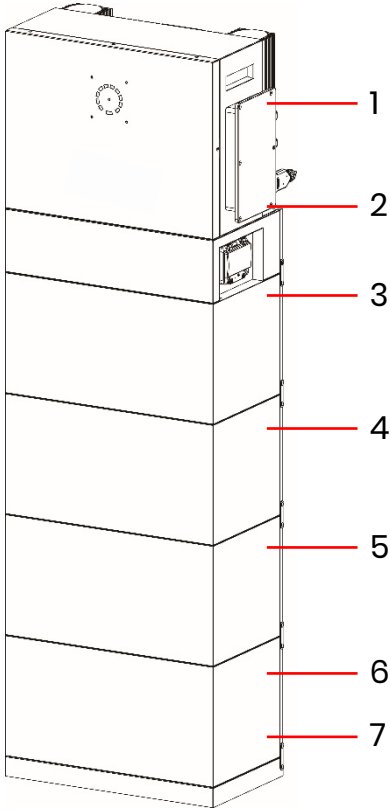

**NOTICE**

Ensure that the high voltage box is installed above the battery boxes. Do not install any battery box above the high voltage box .

This manual will show you the installation and electrical connection of 4 battery boxes.

NO.	Parts
1	Hybrid inverter
2	High voltage box
3, 4, 5, 6	Battery box
7	Base

- Battery appearance

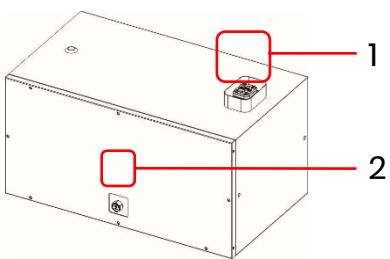

NO.	Parts
1	Guided quick connector
2	Leak valve

- Base appearance

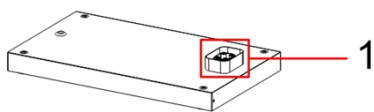

NO.	Parts
1	Guided quick connector
7	Base

● High voltage box appearance

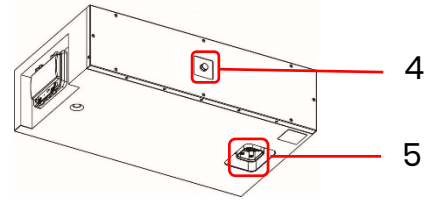
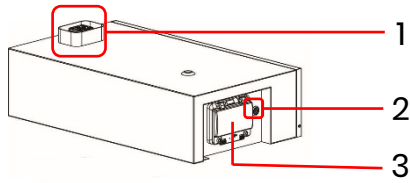

No.	Name	Definition
1, 5	Guided quick connector	Power and communication interface between modules
2	Multifunction button	<p>Black start mode: When there is no PV and grid, press and hold for 5 seconds to start the system and drive the inverter to work.</p> <p>Power off mode: When the system is powered on, press and hold for 5 seconds to turn off the system. If you hear a click, it means the system has been powered off. After turning off via this button, if you want to turn it on again, please press and hold the button for 5 seconds.</p> <p><b>Note</b> After the system is installed for the first time, there is no need to turn it on via this button. Please refer to Chapter 5.2 to turn it on via the DC breaker.</p>
3	DC breaker	The master switch of the battery system, you must switch on it before power on the system; Short circuit protection
4	Leak valve	Battery module safety protection device

● Hybrid inverter appearance

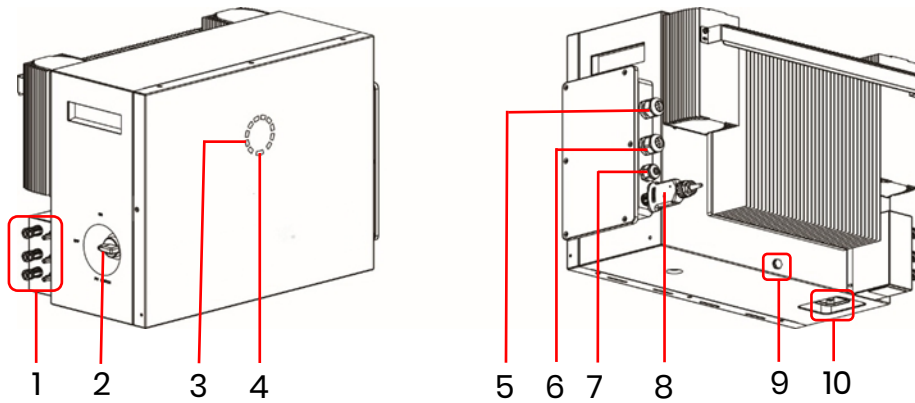

NO.	Parts	NO.	Parts
1	PV connectors	6	Grid connectors
2	PV switch	7	Communication port
3	Charge indicator	8	Wi-Fi dongle
4	Status indicator	9	Leak valve
5	EPS connectors	10	Guided quick connector

**LED INDICATOR:**

STATUS	LED INDICATOR	
Standby		Flashing blue LED, 2-second intervals
Checking		Flashing blue LED, 0.5-second intervals
Normal		Solid blue LED
DSP fault		Solid red LED
Battery com. fault		Flashing red LED, 2-second intervals
Meter com. fault		Flashing red LED, 0.5-second intervals
Charge indicator		

The Status indicator will be solid blue when everything is ready, and the Charge indicator indicates battery power.

### 3.6 Product identity definition

PCS Nameplate:



**Hybrid Inverter:**

<b>Type</b>	WH-TIA133	
<b>PV INPUT</b>	Max. DC input power	20000 W
	Absolute max. voltage	DC 1000 V
	MPPT voltage range	DC 180...980 V
	Max. input current	DC 16/26 A
	Isc PV (absolute max.)	DC 20/36 A
<b>AC INPUT</b>	Nominal voltage	3/N/PE AC 220/380 V
		3/N/PE AC 230/400 V
		3/N/PE AC 240/415 V
	Rated(Max.) current	AC 26 A
	Nominal frequency	50/60 Hz
	Rated(Max.) apparent power	17900 VA
	Nominal power	17900 W
Power factor range	-0.8...+0.8	
<b>AC/EPS OUTPUT</b>	Nominal voltage	3/N/PE AC 220/380 V
		3/N/PE AC 230/400 V
		3/N/PE AC 240/415 V
	Rated(Max.) current	AC 20.8 A
	Nominal frequency	50/60 Hz
	Rated(Max.) apparent power	13000 VA
	Nominal power	13000 W
	AC Power factor range	1(-0.8...+0.8adjustable)
	EPS Power factor range	-0.8...+0.8
	<b>Battery</b>	Battery type
	Battery voltage range	DC 160...700 V
	Max.charge/discharge current	DC 30/30 A
	Ingress protection	IP65
	Operating temperature range	-25°C...+60 °C
	Inverter topology	Non-isolated
	Overvoltage category	III (Grid, EPS), II (PV, BAT)
	Protective class	Class I

DRM0  DRM1  DRM2  DRM3  DRM4  DRM5  DRM6  DRM7  DRM8



**Jiangsu Weiheng Intelligent Technology Co., Ltd.**  
 Address : Sheng Xiang, Yaxi Community, Luoshe Town, Huishan District, 214000, Wuxi City, Jiangsu Province  
 www.weiheng-tech.com Made in China

HV Box Nameplate:



**Rechargeable Li-ion Battery System**

Model/Nominal Voltage/ Energy/Operating Voltage Range	
<input type="checkbox"/>	WH-BXC4992-1S-I/96Vdc/4.99kWh/84~108V
<input type="checkbox"/>	WH-BXC4992-2S-I/192Vdc/9.98kWh/168~216V
<input type="checkbox"/>	WH-BXC4992-3S-I/288Vdc/14.9kWh/252~324V
<input type="checkbox"/>	WH-BXC4992-4S-I/384Vdc/19.9kWh/336~432V
<input type="checkbox"/>	WH-BXC4992-5S-I/480Vdc/24.9kWh/420~540V
<input type="checkbox"/>	WH-BXC4992-6S-I/576Vdc/29.9kWh/504~648V
HV Box Model	HBC571-I
Capacity	52Ah
Ingress Protection	IP65
Operating Ambient Temperature	-20°C~55°C
Nominal Charge/Discharge Current	26A
Max. Charge/Discharge Current	52A
Protective Class	I



**Jiangsu Weiheng Intelligent Technology Co., Ltd.**  
 Address: Sheng Xiang, Yaxi Community, Luoshe Town, Huishan District, 214000, Wuxi City, Jiangsu Province  
 www.weiheng-tech.com Made in China

Battery Nameplate:



**Rechargeable Li-ion Battery**  
 IFpP13/122/360/[30S]M/-20+55/95  
 Rated Capacity:52Ah  
 Model No./Nominal Voltage/Rated Energy :  
 WH-BXC4992/96Vd.c./4.992kWh  
 Max.Charge/Discharge Current:52A  
 Nominal Charge/Discharge Current:26A  
 Operating voltage range:84V...108V  
 Operating temperature range:  
 0°C...+50°C(Charge),-20°C...+55°C(Discharge)  
 Available SOC Range:10%...100%  
 Protective Class:I  
 Ingress Protection:IP65





The battery should be disposed by qualified recycling agent.



**CAUTION**



- Do not disassemble the battery pack.
- Do not immerse the battery pack in water.
- Do not short-circuit the battery.
- Do not leave the battery near by fire.

**Emergency Situations**

- \* If leaking ,fire, wet or damaged ,switch off the breaker and go away from the battery.
- \* Do not touch the leaking liquid .Do not use water.Sand or dry powder extinguisher is usable.

Manufacturer:Jiangsu Weiheng Intelligent Technology Co., Ltd.  
Made in China

### 3.7 Technical Data









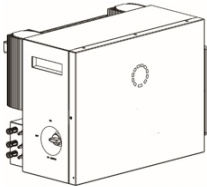

Model	WH-TIA	WH-TIA	WH-TIA	WH-TIA	WH-TIA	WH-TIA
	502 Series	602 Series	802 Series	103 Series	123 Series	133 Series
<b>PV Input</b>						
Absolute max Voltage [d.c.V]	1000					
MPPT Voltage Range [d.c.V]	180...980					
Max. DC Input Power [W]	10000	12000	16000	20000	20000	20000
Start-up Voltage [d.c.V]	145					
Rated Operating Voltage [d.c.V]	620					
Max. Input Current [d.c.A]	16/26					
Isc PV[d.c.A]	20/36					
NO. of MPP Trackers	2					
NO. of Strings per MPP Tracker	1/2					
<b>Battery Model</b>						
Battery Type	LFP					
Battery Voltage Range [d.c.V]	160...700					
Battery Model	4.992kWh, 96V					
Number of Battery Module*	2...6					
Battery Capacity [kWh]	9.98...29.9					
Max. Charge/Discharge Current [d.c.A]	30/30					
<b>AC Input/Output</b>						
Nominal Output Power [W]	5000	6000	8000	10000	12000	13000
Max. Apparent Power to Grid [VA]	5000	6000	8000	10000	12000	13000
Max. Apparent Power from Grid [VA]	10000	12000	16000	17900	17900	17900

Nominal Voltage [a.c.V]	3/N/PE;220/380 3/N/PE;230/400 3/N/PE;240/415					
Nominal Frequency [Hz]	50/60					
Max. AC Current to Grid[a.c.A]	8.1	9.6	12.8	16.0	19.2	20.8
Max. AC Current from Grid[a.c.A]	16.2	19.2	25.6	26.0	26.0	26.0
Inrush current[a.c.A]	16 a.c.A (peak), 11.3 us (duration)					
Max. output fault current[a.c.A]	52 (peak), 37 (rms)					
AC output Maximum output overcurrent protection[a.c.A]	37					
AC input power factor	-0.8...+0.8					
AC output power factor	1(-0.8...+0.8 adjustable)					
THDi	< 3%					
<b>EPS Output (With Battery)</b>						
Nominal Output Power [W]	5000	6000	8000	10000	12000	13000
Peak Output Apparent Power [VA] @60 sec	10000	12000	16000	16000	16000	16000
Nominal Voltage [a.c.V]	3/N/PE;220/380 3/N/PE;230/400 3/N/PE;240/415					
Nominal Frequency [Hz]	50/60 (±0.2%)					
Max. Output Current [a.c.A]	8.1	9.6	12.8	16.0	19.2	20.8
Inrush current[a.c.A]	16 a.c.A (peak), 11.3 us (duration)					
Max. Output fault current[a.c.A]	52 (peak), 37 (rms)					
EPS output Maximum output overcurrent protection[a.c.A]	37					
Switch time [ms]	< 10					
THDv @ Linear Load [%]	< 2					
Power Factor	-0.8...+0.8					
Efficiency						
PV Max. Efficiency[%]	98					
PV Europe Efficiency[%]	97					
PV Max. MPPT Efficiency[%]	99.9					
Battery Charge by PV Max. Efficiency[%]	98.5					
Battery Discharge Efficiency[%]	97.7					
<b>Protection</b>						

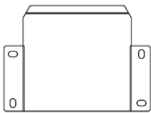
Over/Under voltage protection	Yes
DC isolation protection	Yes
DC injection monitoring	Yes
Residual current detection	Yes
Anti-islanding protection	Yes
Over load protection	Yes
Battery Input reverse polarity protection	Yes
PV reverse polarity protection	Yes
Surge protection	Yes
Over heat protection	Yes
<b>General Data</b>	
Dimension (W/D/H)[mm]	600*350*1880(four battery modules, with base)
Hybrid inverter net weight [kg]	33
Net weight [kg]	30.8
Operation Temp [°C]	-25...+60
Relative Humidity[%]	0...95
Altitude [m]	<= 3000
Ingress Protection	IP65
Cooling	Natural
Inverter Topology	Non-isolated
Over voltage category	III(AC), II(DC)
Protective class	Class I
Active anti-islanding method	frequency shift
Human Interface	LED/APP
BMS Communication Interface	RS485/CAN
Meter Communication Interface	RS485
Noise Emission [dB]	< 25
Standby Power Consumption [W]	< 10

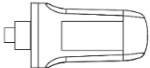
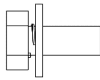
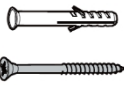
## 4 INSTALLATION

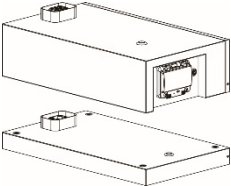
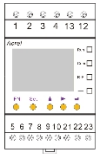
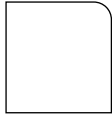
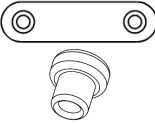
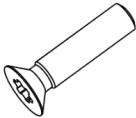
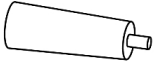
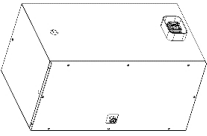
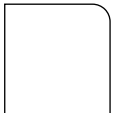
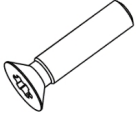
### 4.1 Packing List

WH-TIA502/602/802/103/123/133					
					
1 × PCS	Terminal Accessories	Document Accessories	1 × Quick Installation Guide		
					
1 × Locking Bracket	1 × Metal Bracket	2 × connection plate	1 × Wi-Fi Module		
					
4 × M4*10 screw 6 × M5*10 screw	4 × φ10*60 Expansion bolt	6 × Rubber Stoppers			
WH-High Voltage Box+ WH-Base					
					
1 × High Voltage Box 1 × Base	1 × Meter	Label Accessories	6 × Sheet Metal Bracket 1 × Rubber Stoppers	12 × M4*10 screw	4 × Plastic Handles
WH-BXC5120-1S					
					
1 × Battery Box	Label Accessories	4 × M4*10 Screw	2 × Sheet Metal Bracket	4 × Rubber Stoppers	

## 4.2 Installation Location and Environment

### 4.2.1 General

Install the equipment on a surface that is solid enough to bear the product weight. Please evaluate the load-bearing capacity. The installation location should be well-ventilated and away from flammable or explosive materials.

The product is rated for outdoor installation and can be installed both indoors and outdoors. The product is naturally ventilated. The installation location must be clean, dry, and adequately ventilated. Enough space should be left for unrestricted access to the unit for installation and maintenance purposes, and the system panels should not be obstructed.

The system should not be installed in the following locations:

- ◆ Habitable rooms;
- ◆ Ceiling or wall cavities;
- ◆ On roofs not suited for the purpose;
- ◆ Access/exit areas or under stairs/access passages;
- ◆ Places where freezing temperatures can occur, such as garages, carports, or other places such as wet rooms;
- ◆ Humid or salty environments;
- ◆ Seismic-prone areas—additional safety measures are needed;
- ◆ Sites higher than 2000 meters above sea level;
- ◆ Explosive atmospheres;
- ◆ In direct sunlight or places susceptible to significant changes in ambient temperature.

### 4.2.2 Location Restrictions

The system should not be installed:

- (1) Within 600 mm of any heat source, such as hot water units, gas heaters, air conditioning units, or any other similar appliances;
- (2) Within 600 mm of any exit;
- (3) Within 600 mm of any window or ventilation opening;
- (4) Within 900 mm of access to 380/400/415 VAC connections;
- (5) Within 600 mm of the side of any other device.

Leave at least 1 meter of clearance between the system and any emergency exits when installing the device in corridors, lobbies, or hallways to ensure a safe exit.

### 4.2.3 Barriers to Habitable Rooms

Ensure a suitable non-combustible barrier is set up between the system and any installation walls or structures when installing the system on a wall or structure connected to a living space to protect against the spread of fire to living spaces. A non-combustible barrier should be installed between the system and the surface of the wall or structure it is being mounted to if the surface itself is not made out of a suitable non-combustible material. Increase the distance between the system and any other nearby structures or objects if there is less than 30 mm between the system and the wall or structure separating it from living spaces.

The following spaces around the system must remain empty:

Top	-----	500 mm
Bottom	-----	500 mm
Front	-----	500 mm
Left	-----	500 mm
Right	-----	800 mm

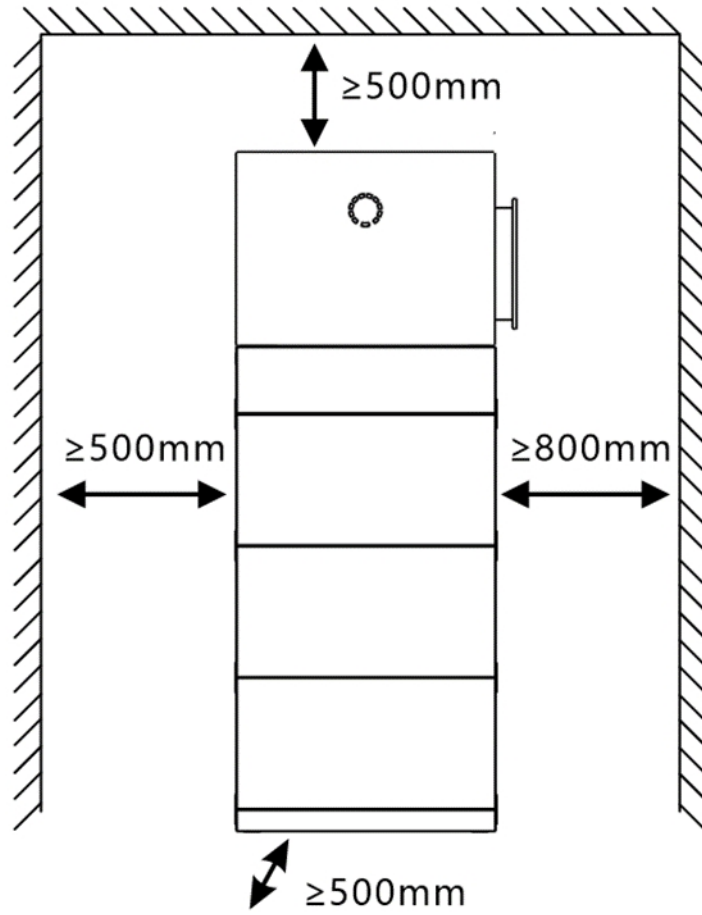

### 4.2.4 Choosing an Installation Location



Carefully select an appropriate installation location based on the following rules to protect the hybrid inverter and facilitate maintenance.

**Rule 1.** Do not install the system at forward tilted, back tilted, side tilted, horizontal, or upside down positions.

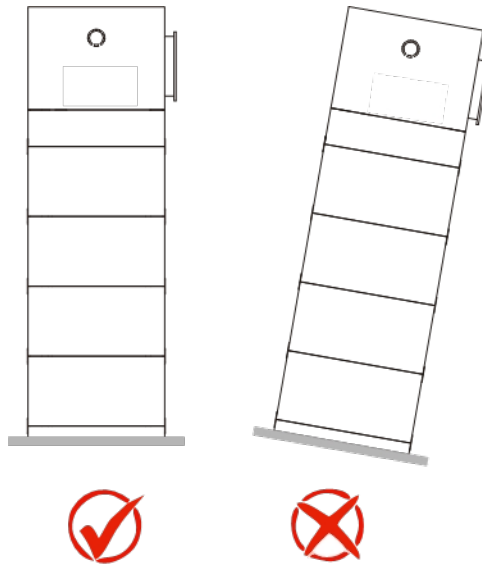

**Rule 2.** Install the system on a solid brick-concrete structure or concrete wall or floor. If other types of walls and floors are used, they must be made of fire-retardant materials and meet the load-bearing requirements of the equipment.

**Rule 3.** During installation, ensure that there is no other equipment (except related Weiheng equipment and awnings) or flammable or explosive materials around the system. Reserve sufficient clearances for heat dissipation and safety isolation.

**Rule 4.** The temperature and humidity at the installation site should be within the appropriate range.

**Rule 5.** The system installation location should be protected from direct sunlight or bad weather like snow, rain, or lightning.

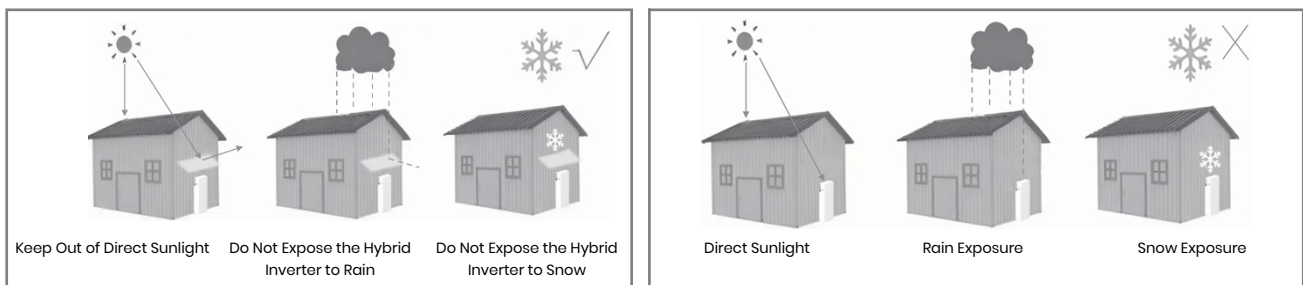

**Rule 6.** Installing the system at eye level will make maintenance more convenient.

**Rule 7.** Install the system at least 500 meters away from the coast and avoid sea

breeze directly hit.

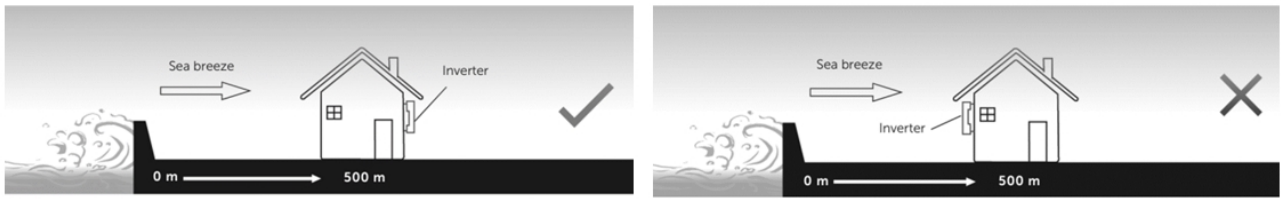

**Rule 8.** The product label should be clearly visible after installation.

**Rule 9.** Do not install the system in the snow or rain. If installation in the snow or rain is unavoidable, ensure the system and distribution box are protected and kept dry.

Install the system away from strong magnetic fields to avoid electromagnetic interference. When installing the system next to radio or wireless communication equipment operating below 30 MHz: 1. Install the system at least 30m away from the wireless equipment. 2. Attach a low-pass EMI filter or a multi-winding ferrite core to the system DC input cable or AC output cable.

### 4.3 Installation Steps



The hybrid inverter must not be installed near flammable or explosive materials or near equipment with strong electromagnetic fields.

The system should only be installed on concrete or other non-combustible surfaces.

Installation Tools:

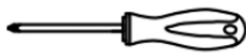

Screwdriver



Multimeter



Wire stripper

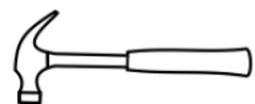

Claw hammer

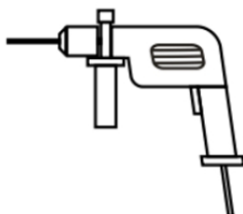

Hammer drill



Diagonal plier

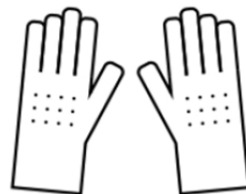

Insulating gloves



Protective gloves

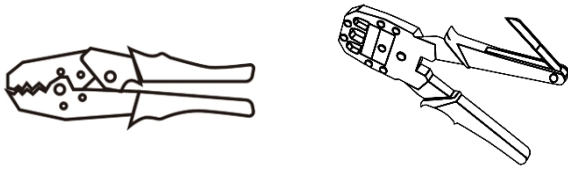

Crimping pliers

**⚠ CAUTION**

- Follow local electric safety and installation policy, a suitable breaker between battery system and inverter is required.
- All installation and operation must follow local electric standard and requirements.
- When battery modules are paralleled, the system should be powered off before installation operation.

**Step1:** Take out the high voltage box and base from the package.

**Step2 :** Place the base on the ground and adjust the height of the bottom support leg with a screwdriver to ensure that the base is horizontal.

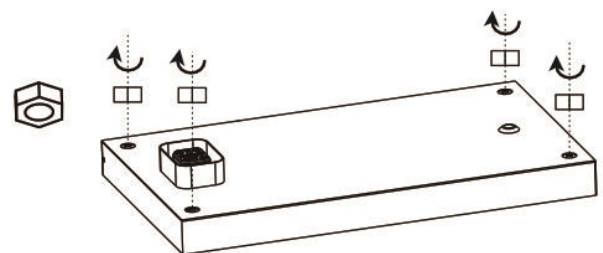
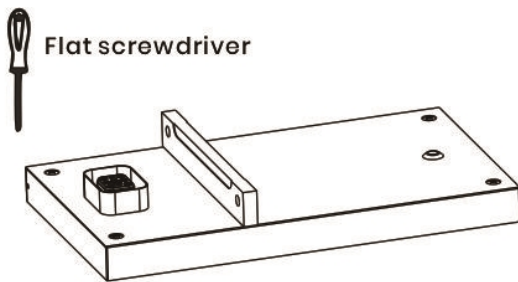

After leveling the base, the four nuts must be tightened

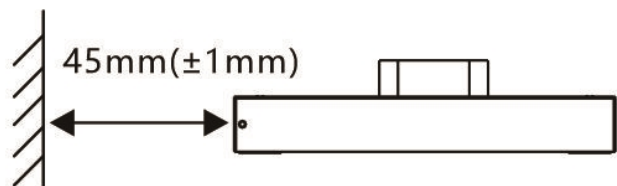
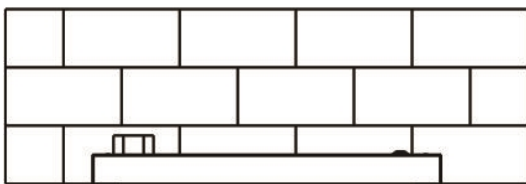

**Step3:** Install the wall-hanging plate of the inverter.

Drill a hole with a diameter of 10mm at the center of the waist-type hole in the back plate with the electric drill and place the plastic expansion tube, then fix the self-tapping screw with a screwdriver. The electric drill must with a dust cover to prevent dust from falling off.

For the hole height, please refer to the definition of H in the following table.

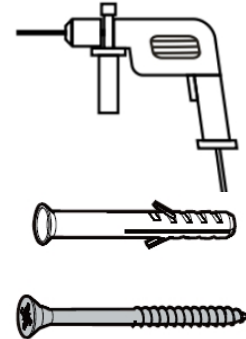
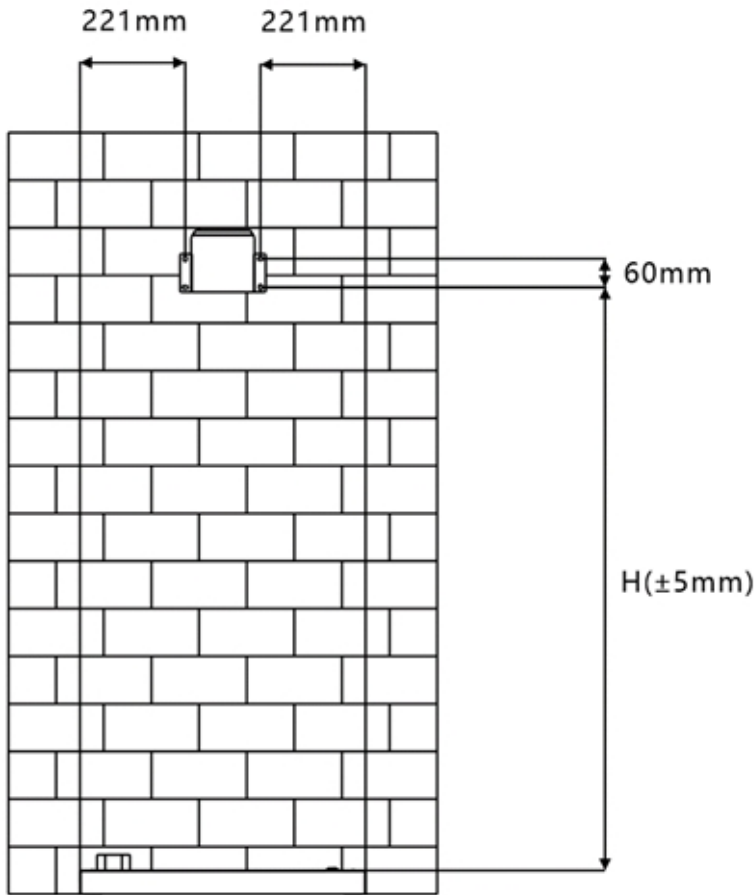

n	H(mm)
2	1062
3	1367
4	1672
5	1977
6	2282

**Step4:** Take out the battery box from the package

**⚠CAUTION**

- Be cautious to prevent injury when moving heavy objects. (The weight of a battery box package is 61.5 kg)
- Use lifting handles to move a battery box. Do not move it directly with your hands.
- Ensure that the lifting handles are securely connected to the battery box, with the steel washers of the lifting handles closely fitted to the battery box. Do not lift the battery box before the lifting handles are tightened.
- The lifting handles are auxiliary moving tools and not applicable to long-distance transportation.
- Do not use a damaged lifting handle. If the stud of a lifting handle is bent, replace the lifting handle promptly.

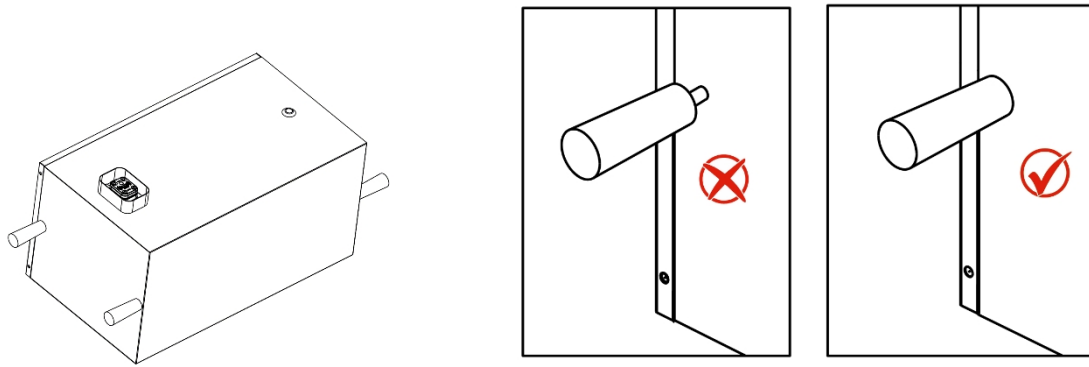

**Step5:** Install the first battery box, stack the battery on the base. Fix the sheet metal brackets on both sides with screws.

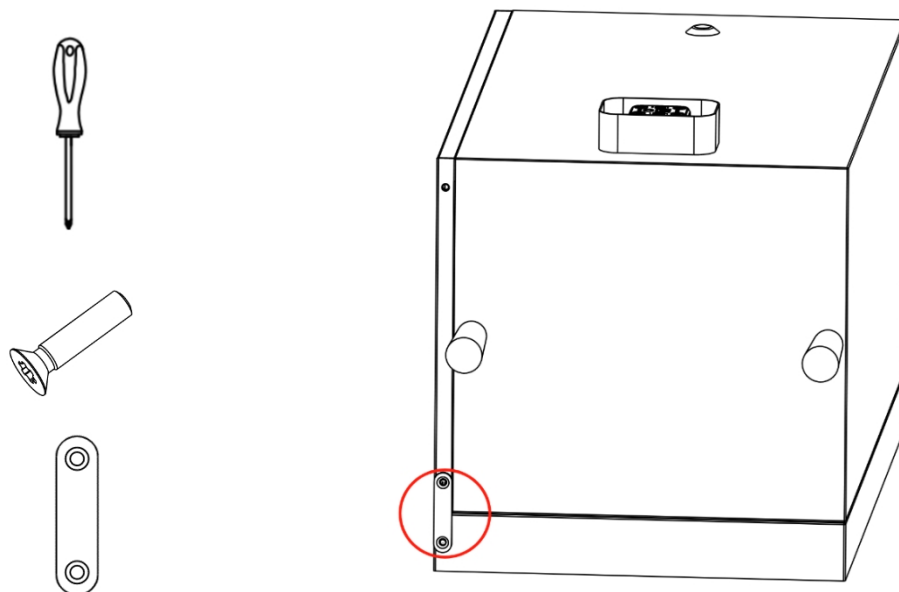
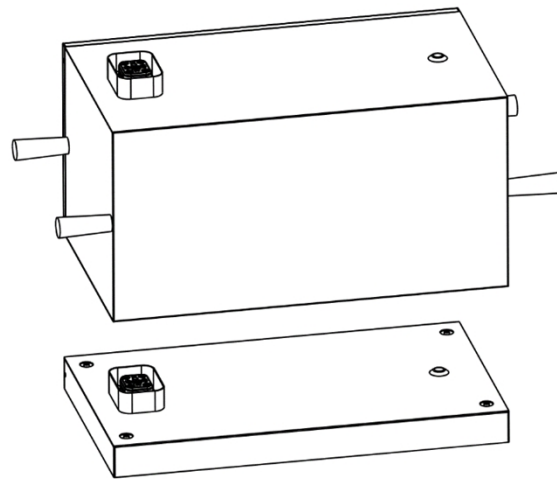

**Step6:** Install all the battery boxes and high voltage box in turn, fix the connecting pieces on both sides.

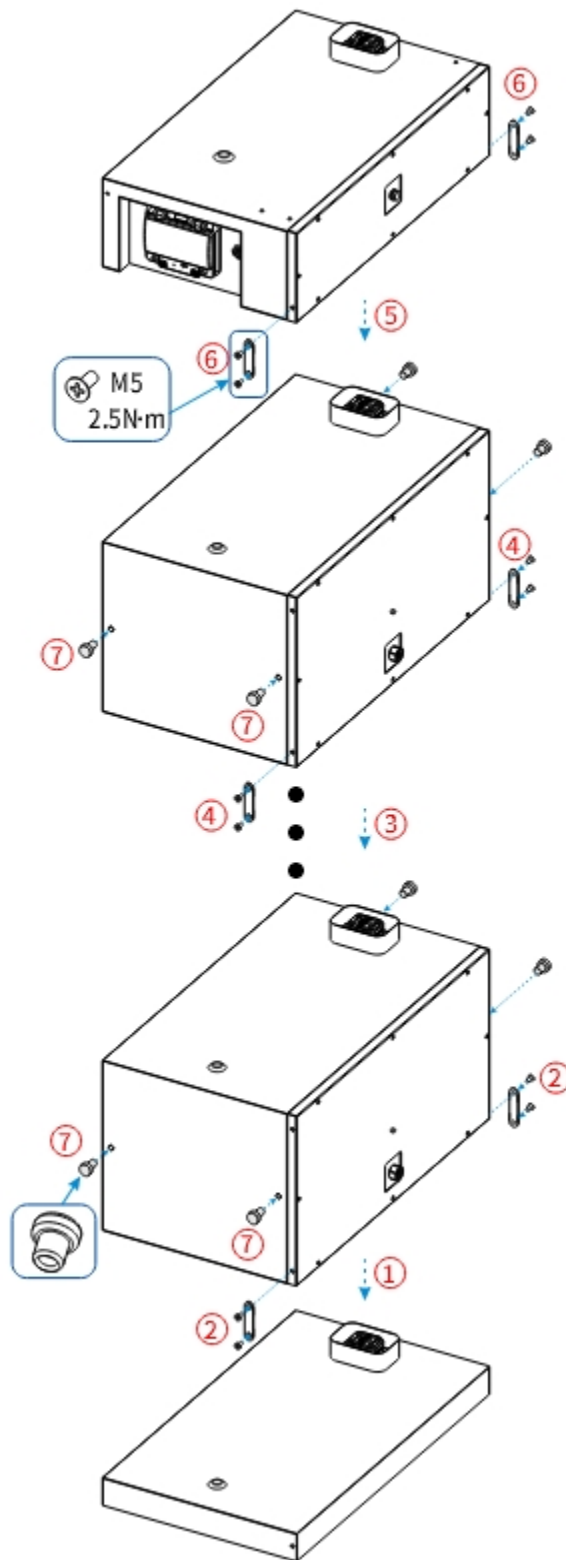

**▲ CAUTION**

- If multiple persons need to move the battery box together, determine the manpower and work division with consideration of height and other conditions to ensure that the weight is equally distributed.
- If two persons or more move the battery box together, ensure that the battery box is lifted and landed simultaneously and moved at a uniform pace under the supervision of one person.
- Wear personal protective gears such as protective gloves and shoes when manually moving the equipment.
- To move the battery box by hand, approach to the battery box, squat down, and then lift the battery box gently and stably by the force of the legs instead of your back. Do not lift it suddenly or turn your body around.
- Do not quickly lift the battery box above your waist. Place the battery box on a workbench that is half-waist high or any other appropriate place, adjust the positions of your palms, and then lift it.
- Move the battery box stably with balanced force at an even and low speed. Put down the battery box stably and slowly to prevent any collision or drop from scratching the surface of the equipment or damaging the components and cables.
- When moving the battery box, be aware of the workbench, slope, staircase, and slippery places. When moving the battery box through a door, ensure that the door is wide enough to move the battery box and avoid bumping or injury.
- When transferring the battery box, move your feet instead of turning your waist around. When lifting and transferring the battery box, ensure that your feet point to the target direction of movement.

**Step7:** Take out the inverter from the package.

**Step8:** Install the metal bracket and connection plate onto the inverter.

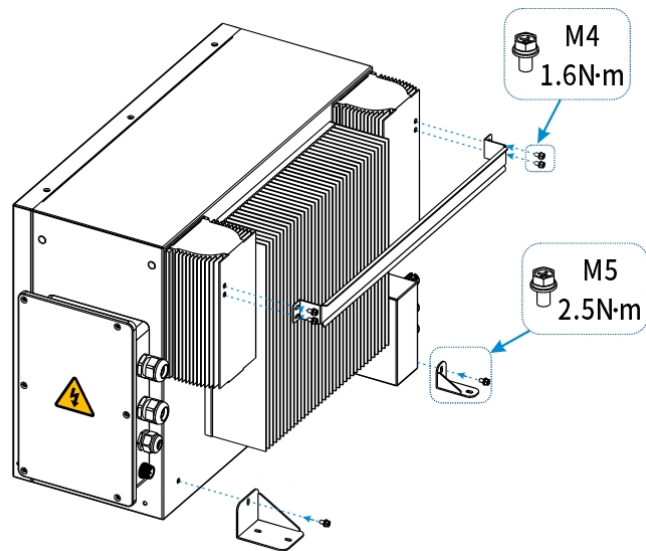

**Step9:** Install the inverter, put the metal bracket of the inverter into the wall-hanging plate and fix the connection plates on both sides.

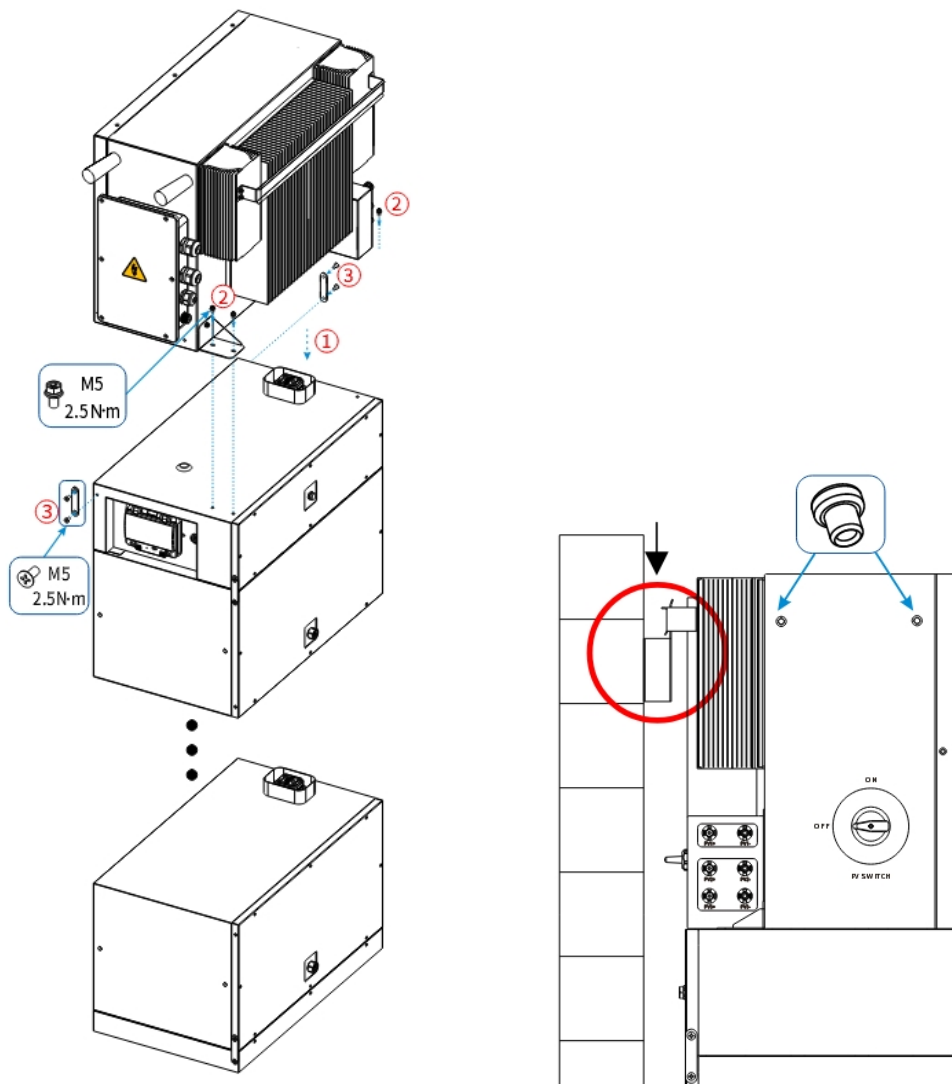

## 4.4 Cable Connections

### 4.4.1 General

Make sure all switches and breakers are in the OFF position.

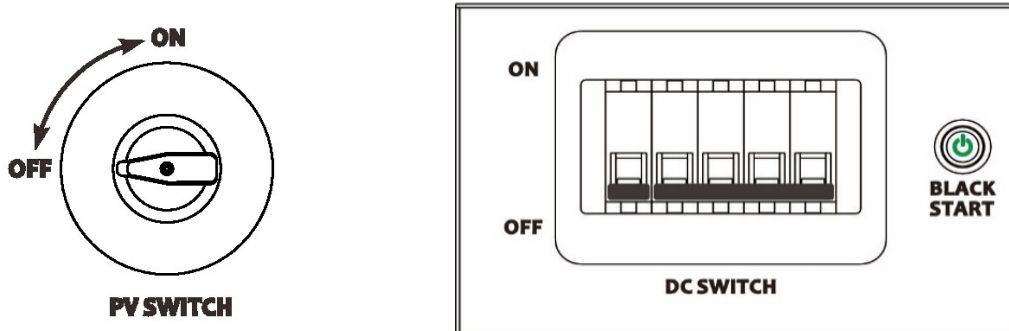

### 4.4.2 Connect the Inverter Box and Battery Box

#### System Wiring Diagram

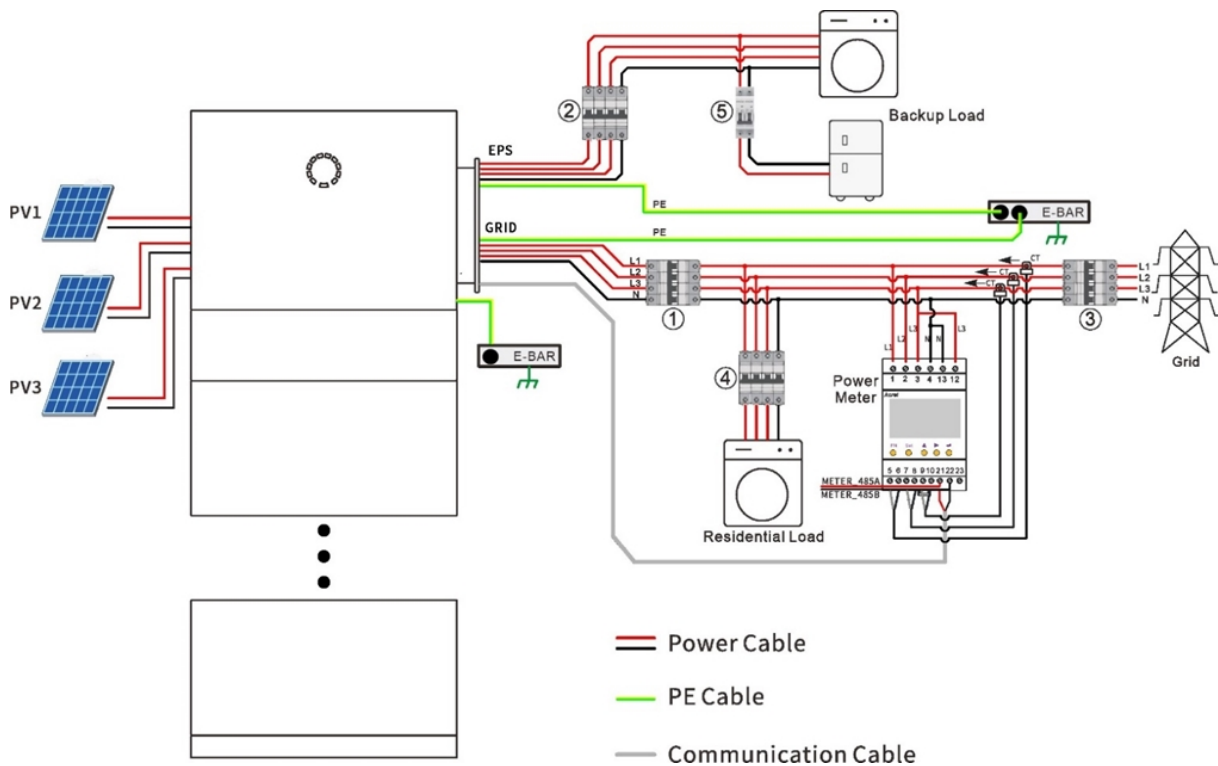

Please use an appropriate breaker based on the following specifications:

#### NOTICE

- Electrical short circuits on the grid side will damage the inverter if an AC breaker is not installed.
- This diagram illustrates the wiring diagram for Agave series hybrid inverters, not the electrical wiring standards.

- Please make sure that the AC line matches the "L1", "L2", "L3", "N", and the grounding port of the AC terminal completely when wiring. If the cable is connected incorrectly, the device may be damaged.

### Choose the correct breaker:

Model	①	② ⑤	③ ④
WH-TIA 502 Series	32 A/230 V AC breaker	16 A/230 V AC breaker	According to residential load (generally already installed in the grid distribution box)
WH-TIA 602 Series	32 A/230 V AC breaker	16 A/230 V AC breaker	
WH-TIA 802 Series	32 A/230 V AC breaker	16 A/230 V AC breaker	
WH-TIA 103 Series	32 A/230 V AC breaker	32 A/230 V AC breaker	
WH-TIA 123 Series	32 A/230 V AC breaker	32 A/230 V AC breaker	
WH-TIA 133 Series	32 A/230 V AC breaker	32 A/230 V AC breaker	

### Recommended cables and connectors:

Cable Type	Cable Specification	Terminal Model
PE Cable	The same as that of the PE wire in the AC cable	OT5-5 (Included in the accessory packet)
PV+ Cable	6mm <sup>2</sup> (RED)	Positive DC Connector (Included in the accessory packet)
PV- Cable	6mm <sup>2</sup> (BLACK)	Negative DC Connector (Included in the accessory packet)
Grid Cable	4-6mm <sup>2</sup>	SV5-5.5 (Included in the accessory packet)
EPS Cable	4-6mm <sup>2</sup>	SV5-5.5 (Included in the accessory packet)
Communication Cable	0.5mm <sup>2</sup>	

**Connect the ground cable, power cable and communication cable, connection process is as below:**

**Step 1:** Open the waterproof cover panel for junction box of user power cable

#### ⚠ CAUTION

- Make sure all switches and breakers turned OFF!
- The product operates at high voltage. All work on the product must be carried out by qualified persons only.

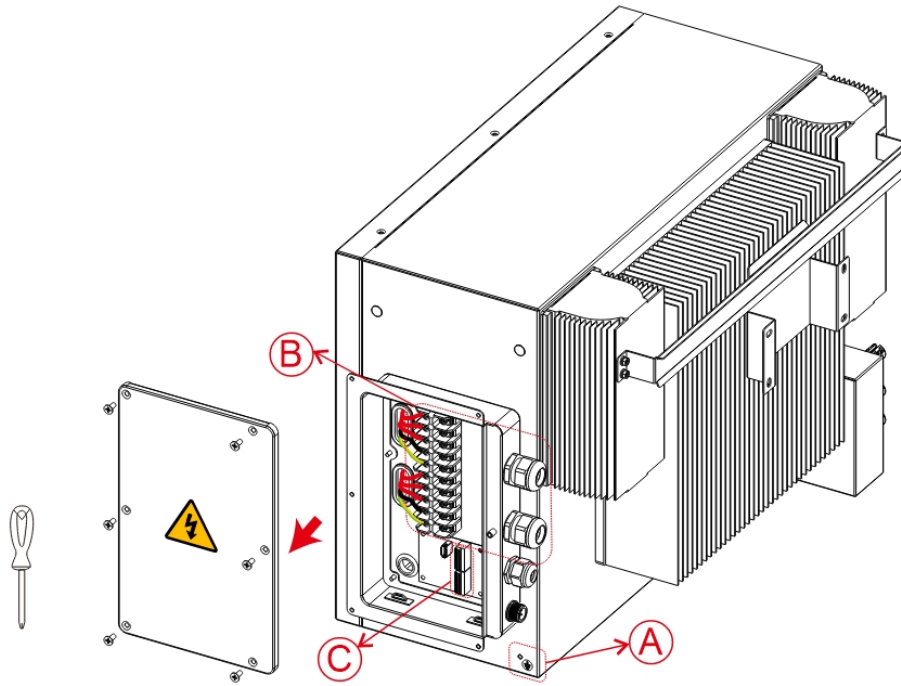

**Step 2:** Connect the PE cable. (A)

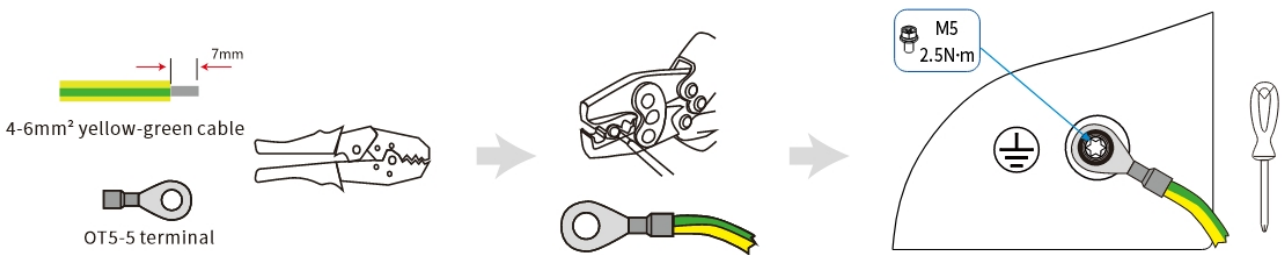

**Step 3:** GRID and EPS cables (B)

**NOTICE**

- An AC breaker should be installed between the inverter and grid. Select the appropriate AC breaker in compliance with local laws and regulations. This will ensure the inverter can be securely disconnected during maintenance and fully protected from over current.
- There are three terminal blocks with "GRID" "EPS" and "GEN" markings. Please do not misconnect input and output connectors.
- Note: Please select the diameter of power cable according to the maximum current of the grid and EPS side. The recommended cable cross-section is 4-6mm<sup>2</sup>.

**WARNING**

- Any load should not be connected with the inverter directly.

1、 Loosen the waterproof connector's press nut and remove the seal. Then, insert the cable into the hole.

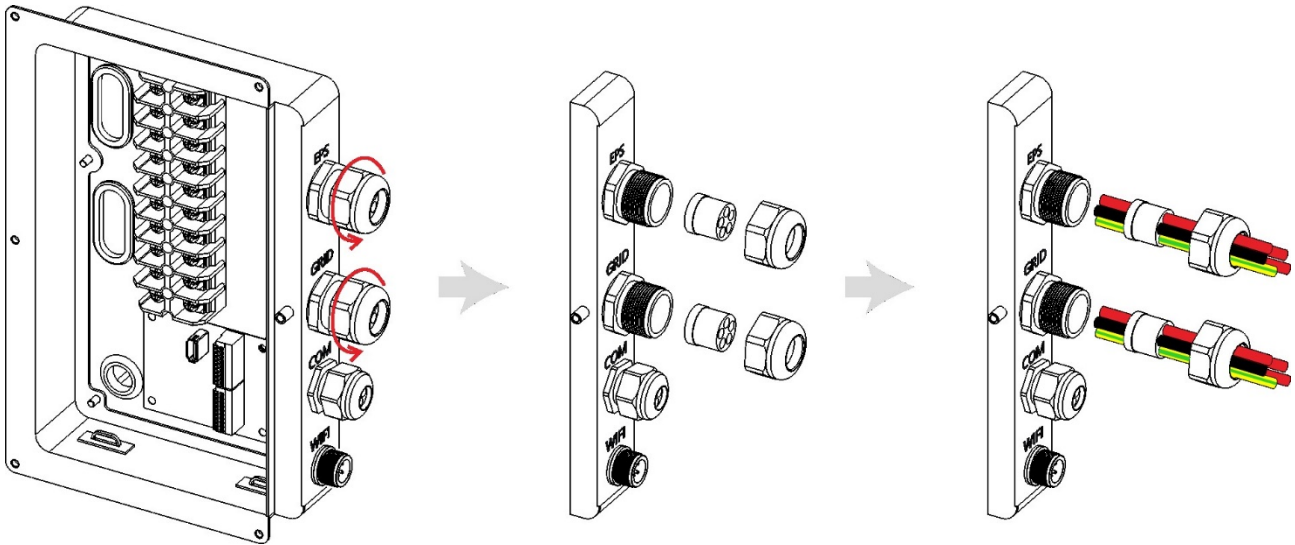

2、 Peel off a 7 mm length of the L/N/PE cable end. Place the SV5-5.5 terminal onto the cable and crimp it tightly using pressure line clamps.

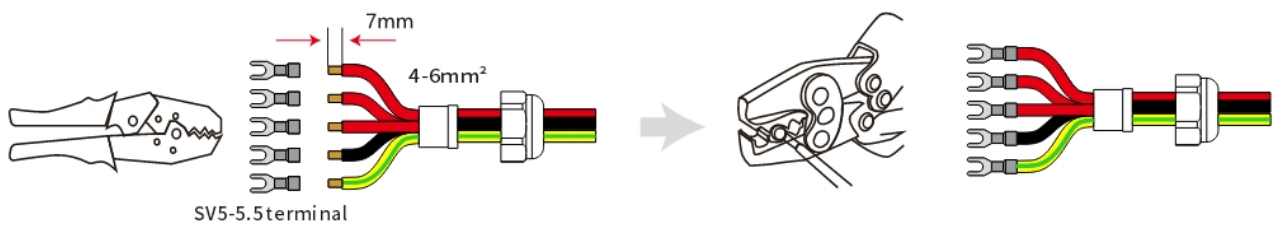

3、 Insert the terminal into the wiring seat, use a Phillips head screwdriver to tighten the screws (2.0 N.m), and tighten the nut.

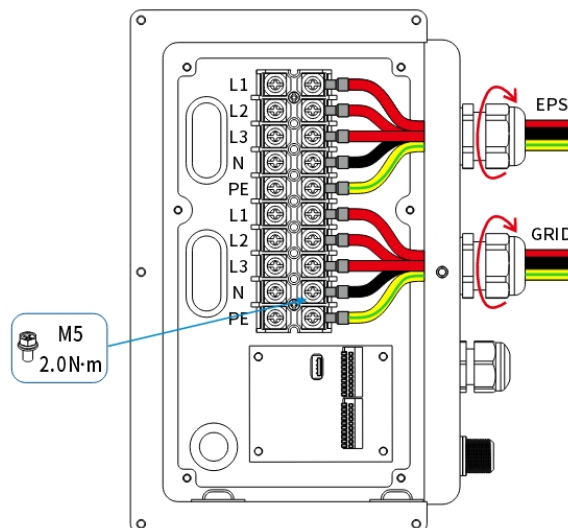

**Step 4:** Connecting the communication cables (C)

1、 Loosen the waterproof connector's press nut and remove the seal. Then, insert the cable into the hole.

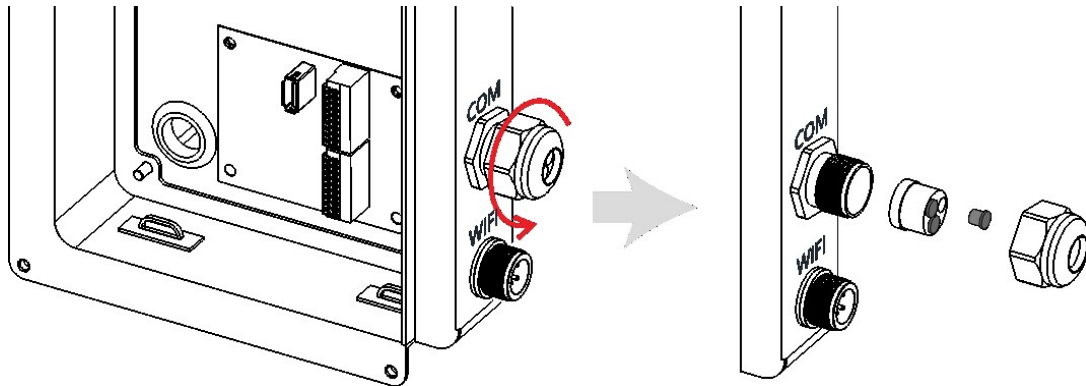

2、 Insert the cable into the hole. Peel off a 11 mm length of the Communication cable end.

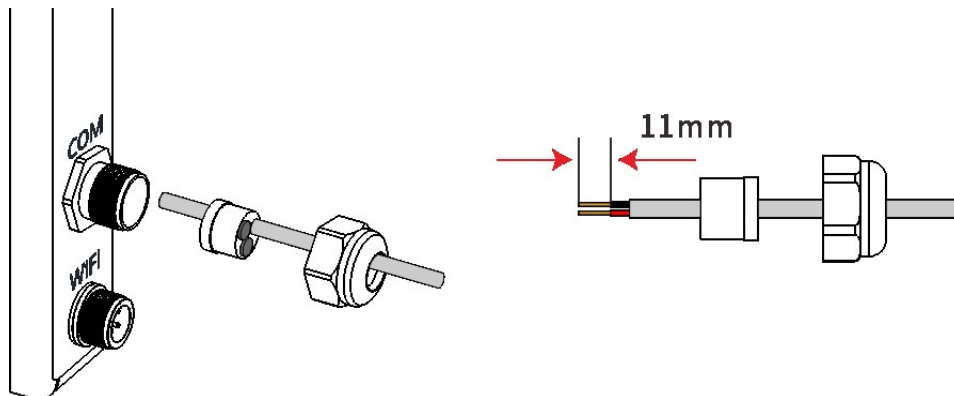
**NOTICE**

- Note: The diameter of communication cable harness should be less than 6mm.

3、 Insert the terminal into the wiring seat, and tighten the nut.

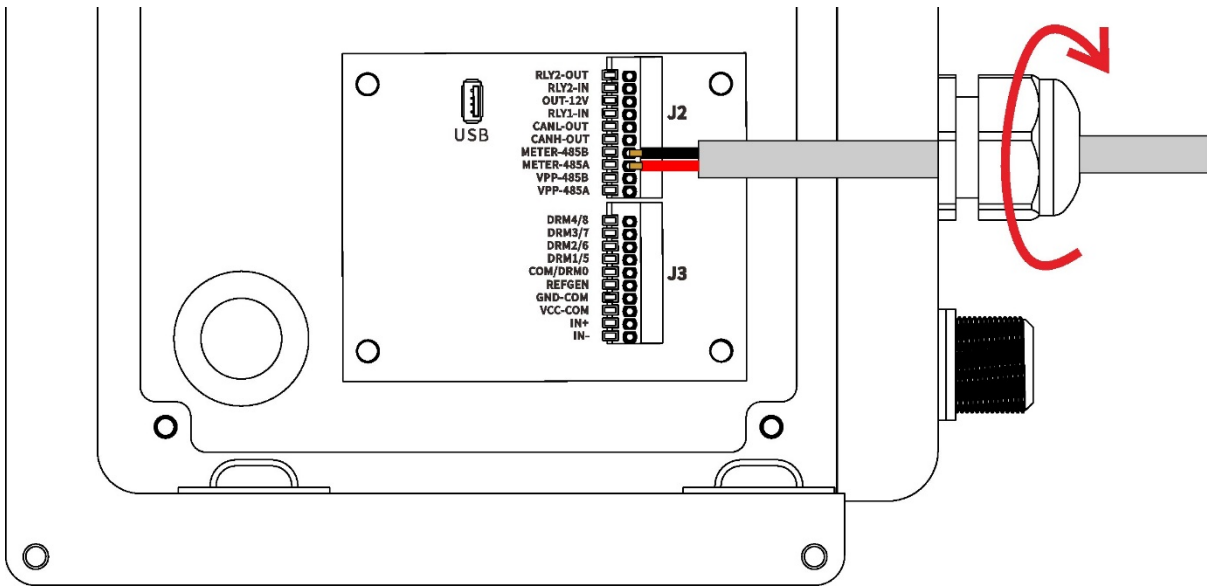

### Three phase meter wiring diagram

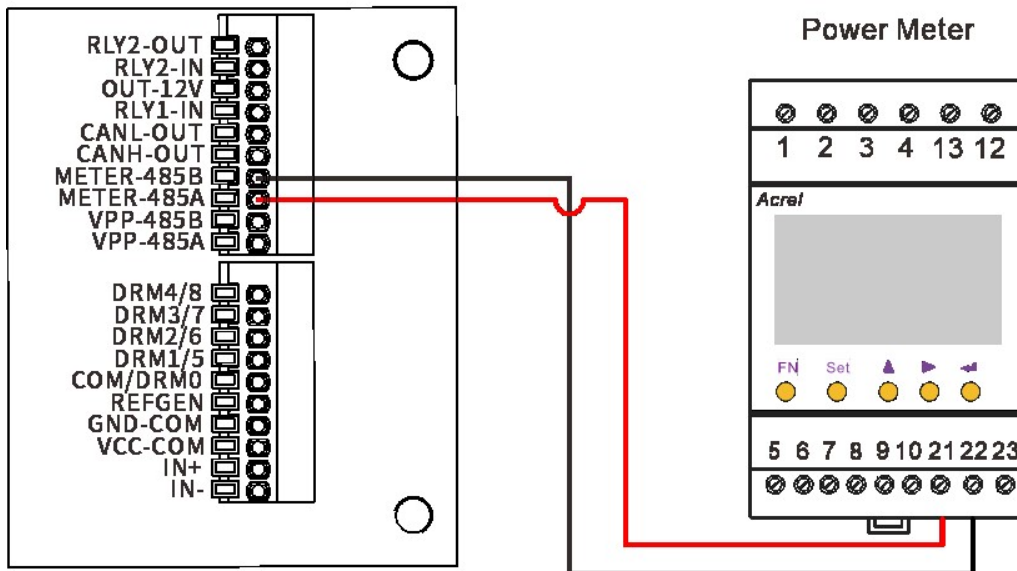

**Step 5:** Insert the Wi-Fi Module, and tighten the nut. Attach the waterproof cover and lock it in place.

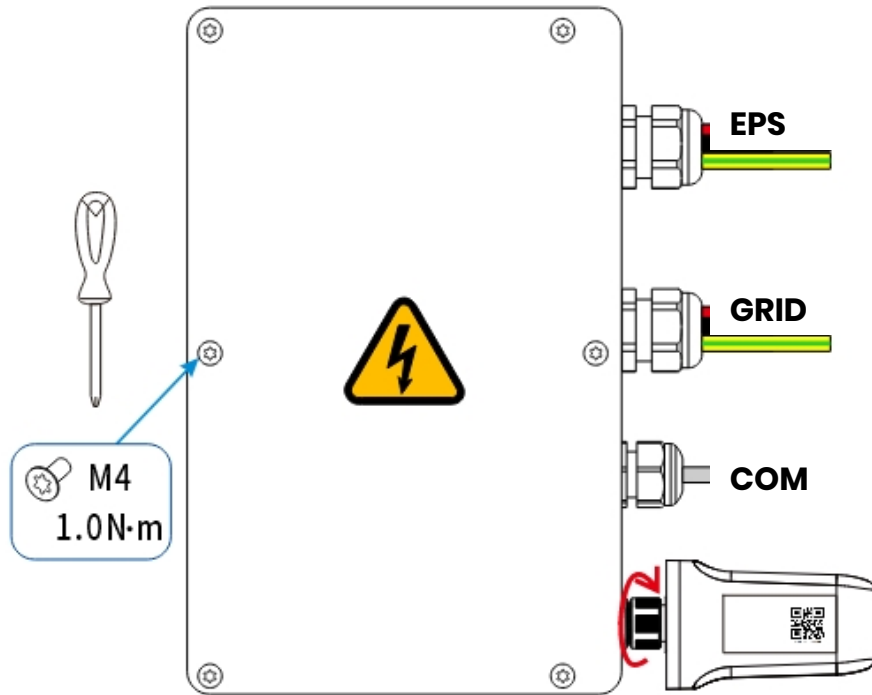

**Step 6:** Connect the PV cables.

**⚠ WARNING**

- PV module voltage is very high and within a dangerous voltage range, please comply with the electric safety rules when connecting;
- Make sure that the max short circuit current and the max input voltage per MPPT are within the permissible range;
- Please make sure to disconnect all the DC and AC switches before any electrical connections. Do not work with power on. Otherwise, an electric shock may occur;
- Please do not make PV positive or negative to ground. Make sure that the positive pole of the PV string connects to the PV+ of the inverter. And the negative pole of the PV string connects to the PV- of the inverter;
- Ensure that the cables are connected securely. Otherwise it will cause damage to the inverter due to overheat during its operation.

**NOTICE**

- To save cable and reduce DC loss, please install the inverter as near to the PV modules as possible.

1. Crimp the terminal;

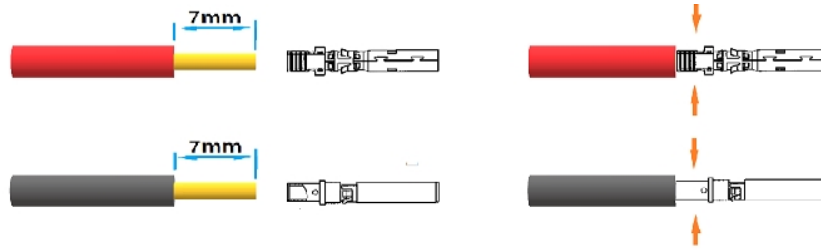

Legend	Description	Value
A	Outer Diameter	5.5–8.0 mm
B	Insulated Cable Length	7 mm
C	Conductor Core	6mm <sup>2</sup>

2. Insert the terminal into the connector and lock the nut;

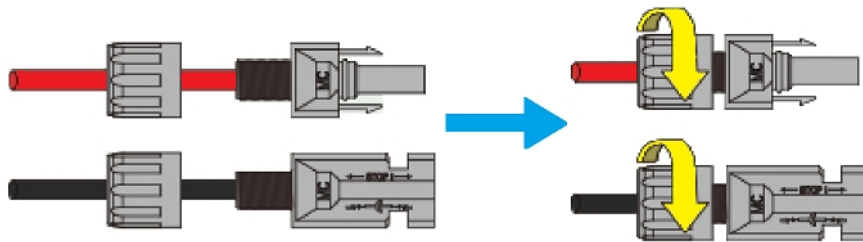

3. Complete the connection.

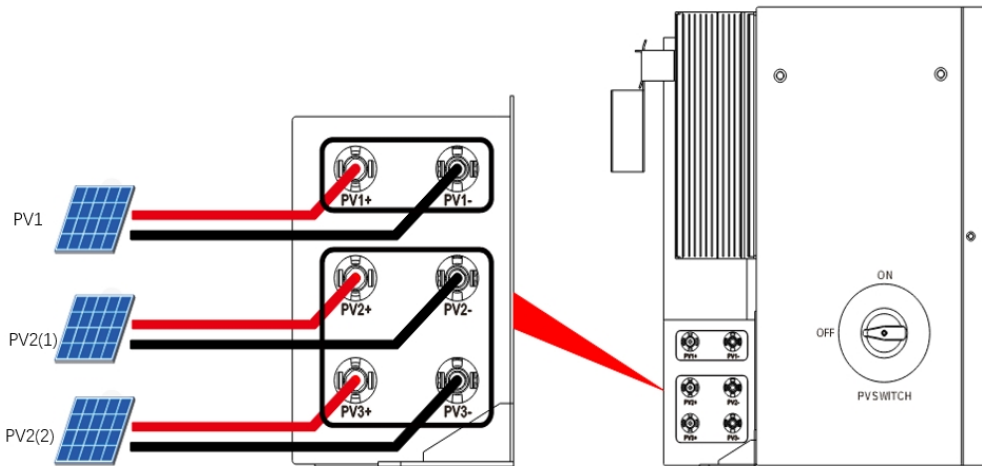

**⚠ CAUTION**

- For the best use of PV power, PV2(1) and PV2(2) should be the same in PV string structure, including the type, number, tilt, and orientation of the PV modules.
- Pay attention to PV string polarity, and do not connect them in reverse order. Otherwise, the inverter might be damaged.

### 4.4.3 System Connection Diagrams

The following diagram illustrates an example use case where the neutral wire is separate from the PE in the distribution box. Please follow local wiring regulations.

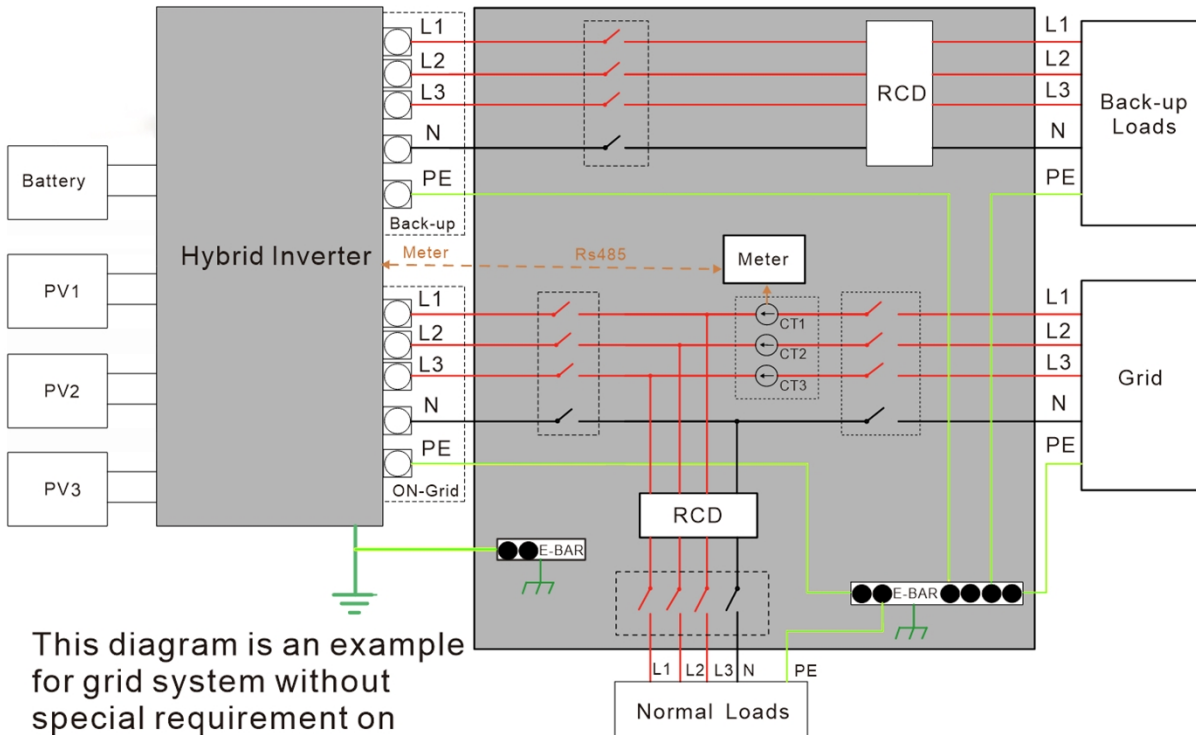

Note: Under Australian safety standards, the Grid and Back-Up neutral wires must be connected together, or the Back-Up function will not work.

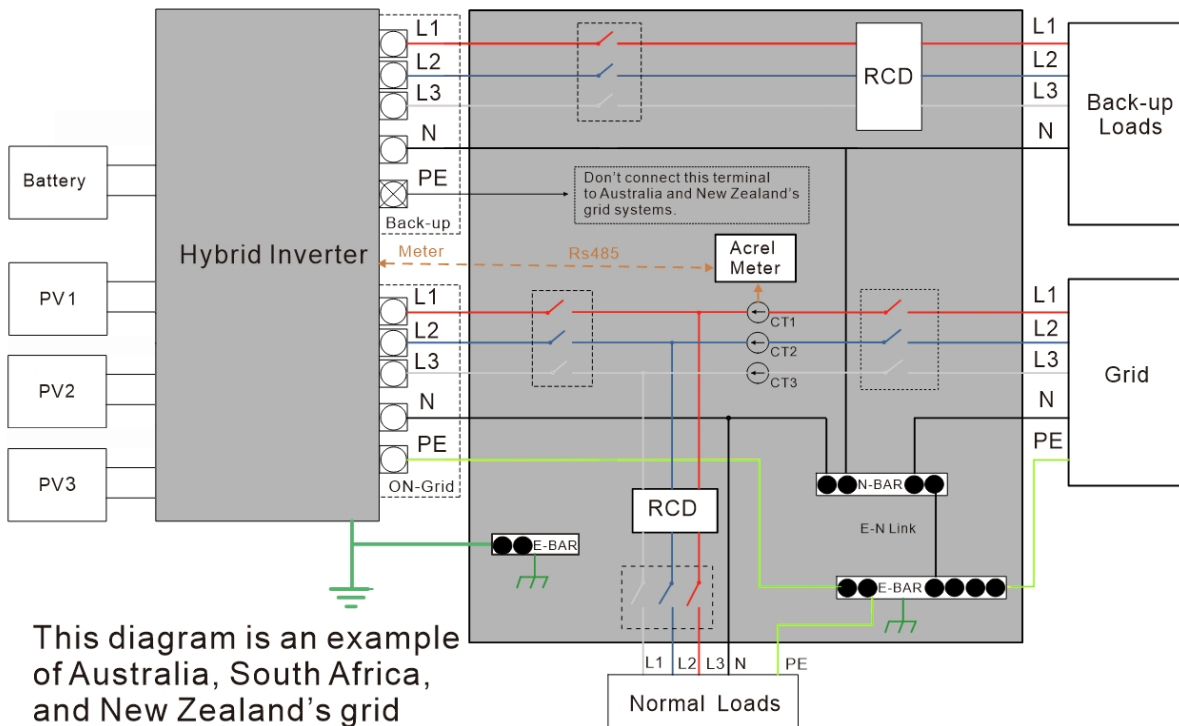

## 5 System Operation

### 5.1 Turning on the system

**Warning: Please double-check the installation before turning on the system.**

**Step 1:** Open the battery breaker cover and turn the battery breaker to the ON position.

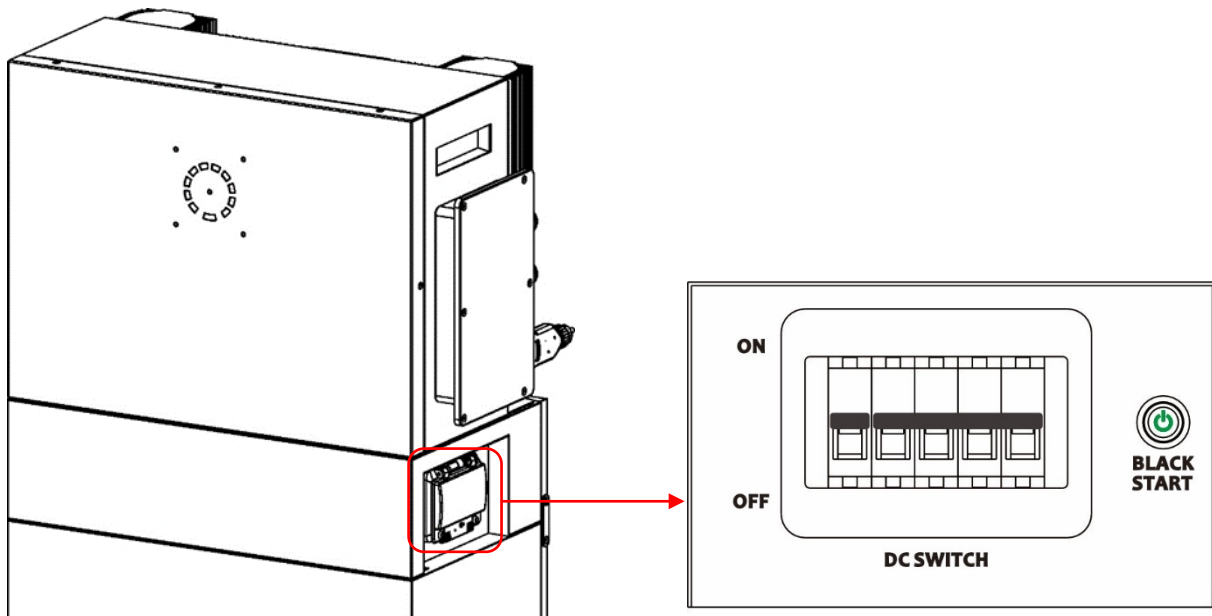

**Step 2:** Turn on the PV switch.

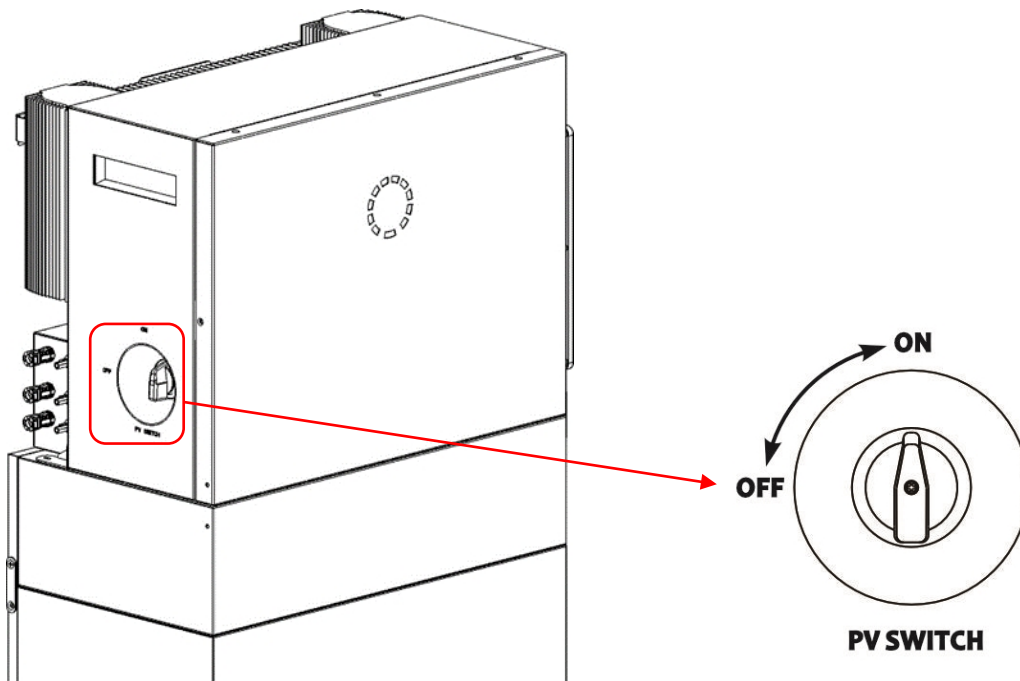

**Note:** The external isolation devices for PV array ports shall include the requirement of an additional external break switching device that conforms to the requirements AS/NZS 4777.1

**Step 3:** Turn on the grid breaker.

**Step 4:** Turn on the backup breaker if a backup load is being used.

**Step 5:** Close the battery breaker cover.

**Step 6:** Configure the Wi-Fi dongle (Only when turning on the system for the first time).

## 5.2 Turning off the system

**Step 1:** Disconnect the backup load where applicable, and then turn off the backup breaker.

**Step 2:** Turn off the grid breaker.

**Step 3:** Turn off the PV switch.

**Step 4:** Open the battery breaker cover and turn the battery breaker to the OFF position.

**Step 5:** Close the battery breaker cover.

## 6 CONFIGURATION & WI-FI RELOAD

This part demonstrates the configuration step by step.

### 6.1 Preparations

1. A router connected to the Internet is required to connect to the ECOS application center.
2. Android or iOS smartphone.

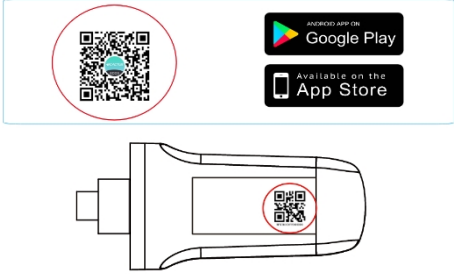
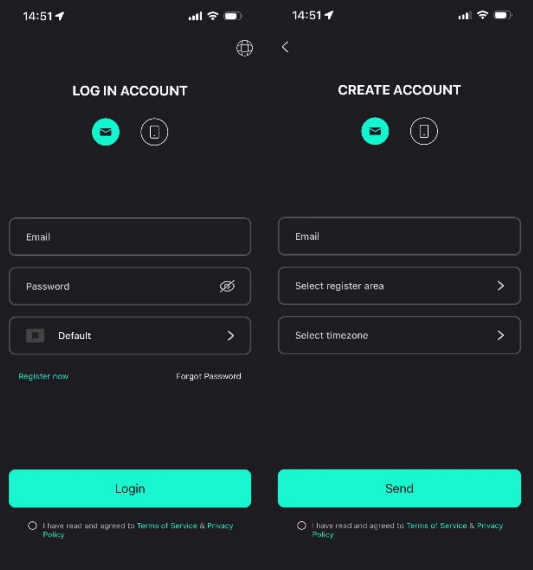
<p><b>STEP 1</b></p> <ol style="list-style-type: none"><li>1. Scan the QR code on the front of the device to install the Android or iOS version of the ECOS app, depending on your operating system.</li></ol>	
<p><b>STEP 2</b></p> <ol style="list-style-type: none"><li>1. Open the ECOS app and tap the sign-up button to register a new user account.</li><li>2. Follow all the instructions given during the sign-up process to successfully connect the device to ECOS.</li><li>3. The product ID QR code required for connection can be found on the included Wi-Fi dongle installed on the right side of the device.</li></ol>	

**NOTICE**

- Please ensure the correct router password is entered.
- Make sure that the Wi-Fi dongle's wireless network connection is strong.
- If everything is set up properly, the Wi-Fi LED on the inverter will change from slowly flashing to quick flashing and then become solid, indicating that the device has successfully connected to the Wi-Fi network.

## 6.2 Wi-Fi Reset & Restore

Wi-Fi Reset: Reconfigure the Wi-Fi dongle, and Wi-Fi settings will be reprocessed and saved.

Wi-Fi Restore: Restore the Wi-Fi dongle settings back to the default factory settings.

**Wi-Fi Reset:**

Please use your ECOS app to reset the Wi-Fi configuration.

Navigate to Settings and My Devices, access the Wi-Fi Configuration page, and follow the instructions to complete the Wi-Fi process.

**Wi-Fi Restore:**

You also need to configure Wi-Fi network after set Wi-Fi dongle back to factory setting.

**Wi-Fi Reset:**

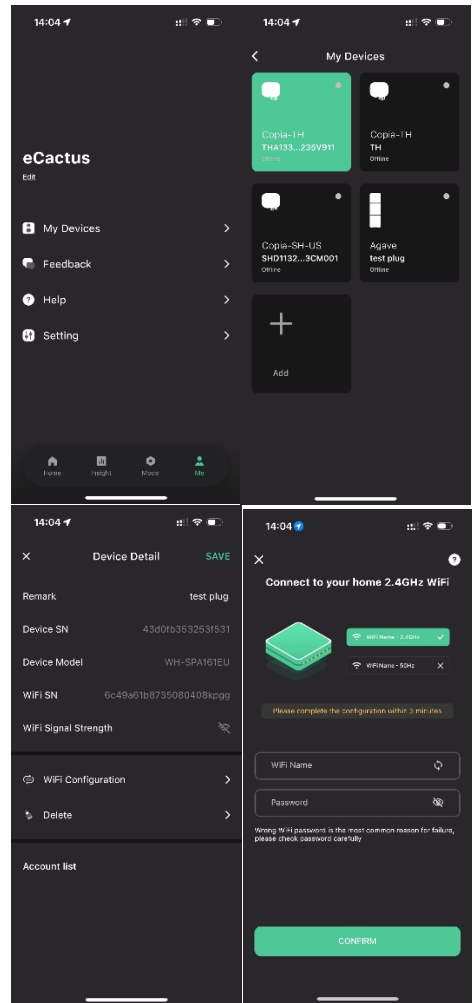

**Wi-Fi Restore:**

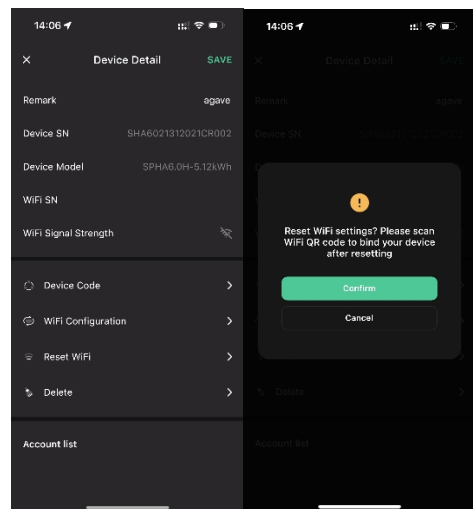

### 6.3 Change Password & Delete Account

#### Change Password

You can change your password by navigating to “**Settings**” >> “**Security**” >> “**Change Password**” and entering your Original Password to set a new password.

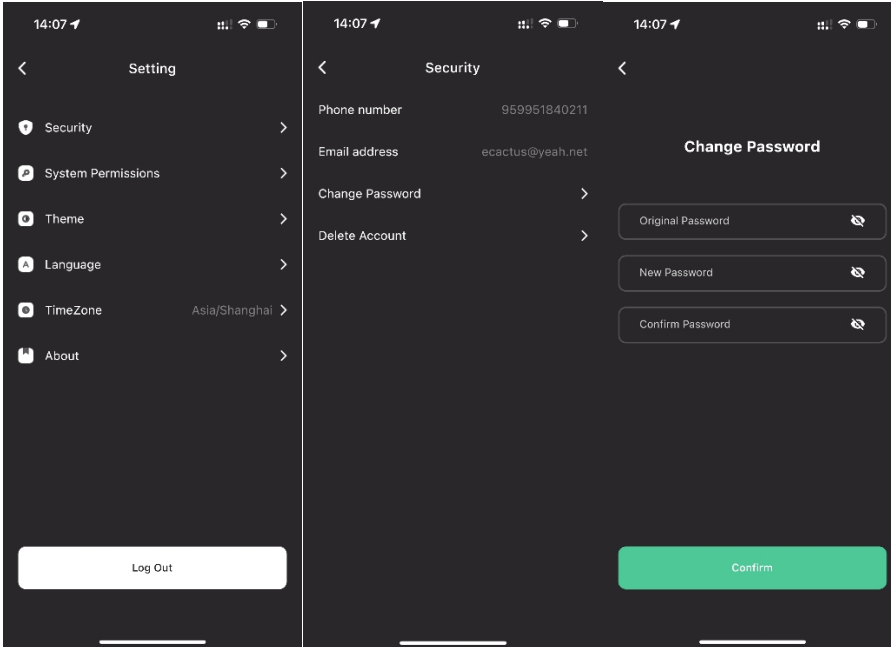

If you forget your password, you can reset your password by tapping “**Forgot Password**” on the login page and entering the verification code sent to your email address.

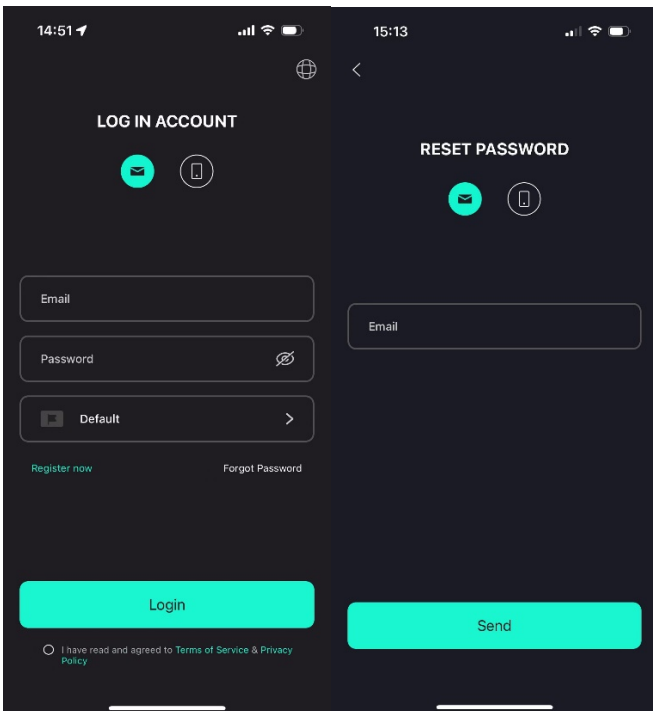

## Delete Account

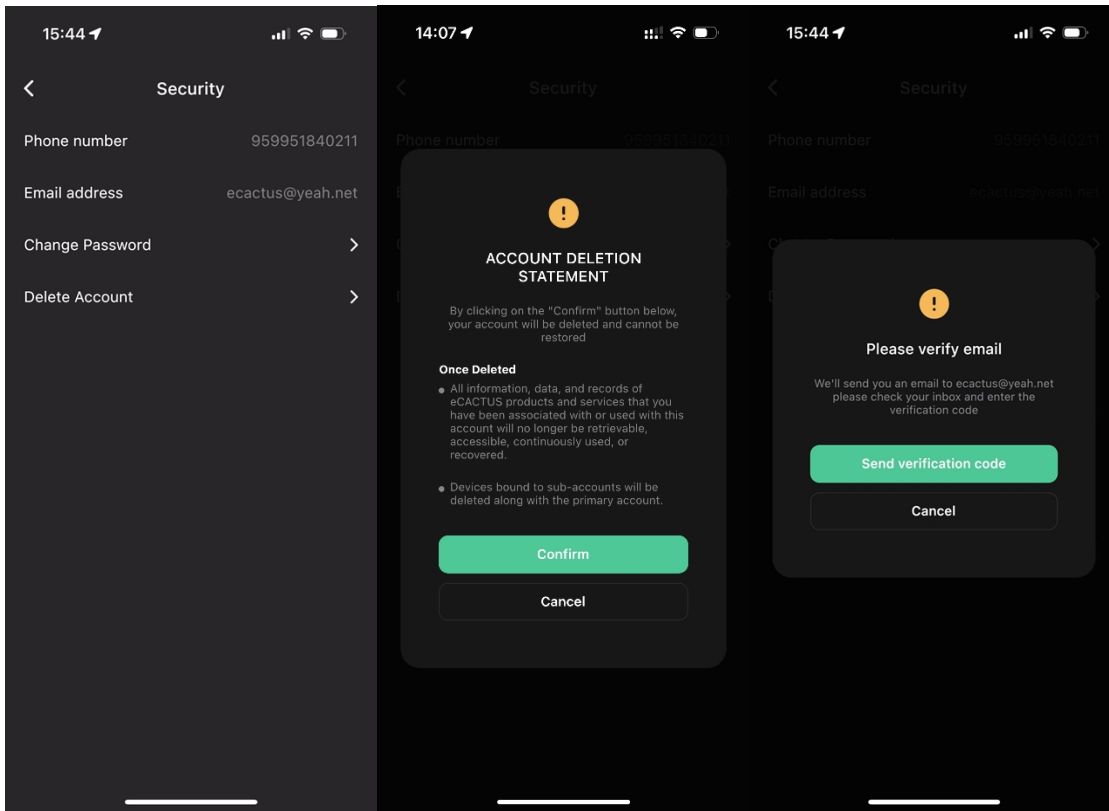

You can delete your account and data by navigating to “**Settings**” >> “**Security**”>> “**Delete Account.**” Please read the statement carefully before deleting your account.

**Notice:** You have 7 days to log back in and cancel your deletion request. Once deleted, your account and all associated data will be erased and cannot be recovered. When complete, we will send an email to your ECOS account to inform you that your account has been successfully deleted.

## 7 EMS CONFIGURATIONS

Energy management system (EMS) configurations can be set via the ECOS app or online website.

**Three working modes can be configured:**

### 1. Self-Powered:

EMS will manage residential power to minimize power grid reliance.

### 2. Load Shifting:

Batteries will be charged and discharged as configured.

### 3. Backup:

EMS will not discharge the battery unless the power grid is off. When this happens, EMS will provide residential power through the batteries.

#### Working Modes:

Navigate to the Customize tab and select one of the three operation modes via the ECOS app.

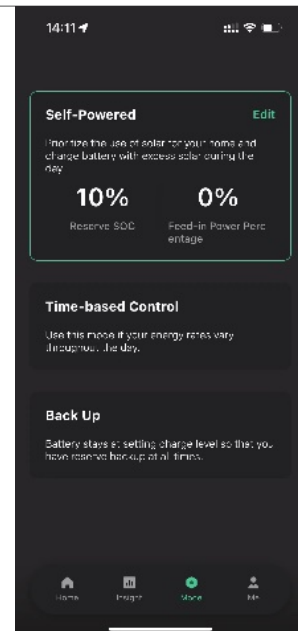

## 8 TROUBLESHOOTING

	Issue	Solution
1	Red LED flashing every 0.5 seconds	Meter Communication Fault. Please check whether the power supply & communication cables are properly connected in accordance with local standards.
2	Red LED flashing every 2 second	Battery Communication Fault. Please check whether the PCS is properly connected to the battery box, and make sure that the battery switch and breaker are both in the ON position.
3	Abnormal ECOS Energy Flow Monitoring	Please check whether the power supply and CT have been properly installed according to the installation manual.
4	All the LEDs are off	Please check whether the voltage at each port is within the normal range.
5	SOC mis-indicates and fluctuates after initial installation	Do nothing, and the device will self-correct itself as soon as the battery is fully charged or discharged.
6	Battery completely depleted	We highly recommend disconnecting the battery ASAP during installation or when the device is on standby to avoid serious depletion and damage caused by extreme power consumption over a long period of time. Please contact after-sale services for technical support in the event of serious battery depletion.
7	Code DSP_1	PV1 overvoltage. Please check whether the open circuit voltage is within the normal voltage range.
8	Code DSP_2	PV1 overcurrent. Please check whether PV1 is correctly connected.
9	Code DSP_3	PV2 overvoltage. Please check whether PV2 is within the rated voltage range.
10	Code DSP_4	PV2 overcurrent. Please check whether PV1 is correctly connected.
11	Code DSP_9	Please check whether PV is within the normal voltage range.
12	Code DSP_10	No grid power. Please check whether the grid voltage is normal.

	Issue	Solution
13	Code DSP_11	Grid voltage fault. Please check whether the grid voltage is within the normal range.
14	Code DSP_12	Grid current fault. Please check whether the EPS load power is within the normal range.
15	Code DSP_13	Grid frequency fault. Please check whether the grid frequency is within the normal range.
16	Code DSP_14	Overheat fault. Please check whether the cooling system is working properly.
17	Code DSP_16	Current over-leak fault. Please check the solar panel and device wiring.
18	Code DSP_17	Isolation resistance fault. Please check the solar panels and wiring system.
19	Code DSP_26	Battery voltage fault. Please check whether the battery voltage is within the normal range.
20	Code DSP_37	EPS voltage fault. Please check whether the EPS load power is within the normal range.
21	Code DSP_38	EPS current fault. Please check whether the EPS load power is within the normal range.
22	Code DSP_39	EPS overload fault. Please check whether the EPS load power is within the normal range.
23	Code DSP_40	EPS short circuit fault. Please check whether the EPS load power is within the normal range.
24	Code DSP_41	Earth & Neutral wire fault. Please check whether the earth and neutral wires are properly wired in line with standard requirements.
25	What should I do if I forget my ECOS password?	Please use the ECOS app, tap "Forgot Password", enter your email address for verification, and follow the instructions to reset your password.
26	How can I change my ECOS password?	Log into ECOS and navigate to "Me" >> "Setting" >> "Security" >> "Change Password" to enter your new password.
27	How can I delete my device account?	Log into ECOS, then navigate to "Me" >> "Setting" >> "Security" >> "Delete Account." Complete email verification to request Account Deletion. Deletion requests can be canceled by logging in within 7 days after requesting account deletion. All account data will be deleted and will not be

	Issue	Solution
		recoverable. Please think twice before deleting your account.
28	How can I share my ECOS account with my family members?	The first ECOS registered will be recognized as the master account, and others can scan the Home code shared by the master account. Please navigate to "Me" >> "Home Management" >> "Home Center" >> "Invite member" to share the code.
29	Why is there no data on the home page?	The device may be offline. 1.Check whether your Wi-Fi is working; 2.Check whether the LED is on; 3.Check whether the Wi-Fi dongle is properly connected; Data may take a while to upload, after which ECOS will be bound to the device. Poor mobile phone reception. Check whether the internet is working properly and try to restart ECOS.
30	Adding multiple devices to ECOS	Log in to the ECOS app and tap the "+" on the top left of the home page. Scan the QR code on the Wi-Fi dongle to add new devices. Or navigate to "Deviceand" tap the "+" on the top left of the "My Devices" page to add more devices.
31	How can I delete my device account?	Log in to ECOS and navigate to "Setting" >> "My Devices," select the device account, and tap the top right of the screen to delete the device.
32	Why is the device offline	There are many possible reasons for the device to be offline. 1.Check whether the Wi-Fi network is working properly; 2.Check whether the LED is on; 3.Check whether the LED on the Wi-Fi dongle is on.
33	Why can't I search for and find the Wi-Fi dongle hotspot?	1.Check whether the LED is on; 2.Check whether the LED on the Wi-Fi dongle is on; 3.Restart or reconnect the Wi-Fi dongle.
34	Why is no internet connection found when returning to other interfaces after	Disconnect your mobile phone from the WLAN, and reconnect it to your home Wi-Fi or your mobile network after successfully configuring WLAN.

	<b>Issue</b>	<b>Solution</b>
	configuring ECOS via WLAN?	

## 9 EMERGENCIES

### 9.1 Emergency Procedures

Turn off the main grid breaker directly feeding the inverter and turn off all inverter switches if the WH-THA inverter appears to be malfunctioning. Please immediately contact WHES for detailed instructions.

**WARNING: Do not open the inverter upper cover plate by yourself.**

### 9.2 First Aid Procedures

Avoid touching any liquid or gas leaking out of battery modules. Immediately do the following upon exposure to leaked battery liquids or gases:

**Skin contact:** Remove any contaminated clothes and rinse the affected area with plenty of water or run it under a shower for at least 15 minutes. Seek medical attention immediately.

**Eye contact:** Immediately flush the eyes with plenty of water for at least 15 minutes, occasionally lifting the upper and lower eyelids. Seek medical attention immediately.

**Inhalation:** Cover the victim in a blanket, move them into the fresh air, and keep them calm. Seek medical attention immediately. Begin artificial respiration immediately in the event of shortness of breath or difficulty breathing, or asphyxia (choking).

**Ingestion:** Give the patient at least 2 glasses of milk or water to drink. Induce vomiting unless the patient is unconscious. Seek medical attention immediately.

### 9.3 Firefighting Measures

**Extinguishing media:** Dry powder, sand, carbon dioxide (CO<sub>2</sub>). Fire precautions and protective measures:

**Flammable properties:** Lithium-ion batteries contain a flammable liquid electrolyte that may vent, ignite, or produce sparks when subjected to high temperatures (> 150°C) or when damaged or improperly used (e.g., mechanical damage or overcharging). Burning cells can ignite other batteries close by.

**Explosion data:** Severe mechanical abuse may rupture batteries. Batteries may explode when exposed to fire.

**Special protective equipment for firefighters:** Wear full protective gear and self-contained breathing apparatus with a full face mask in a pressure-demand or other positive pressure mode in case of fire.

## 10 Remarks

### 10.1 Recycle and Disposal

In case a battery (normal condition or damaged) needs disposal or needs recycling, it shall follow the local recycling regulation (i.e. Regulation (EC) N° 1013/2006 among European Union) to process, and using the best available techniques to achieve a relevant recycling efficiency.



### 10.2 Maintenance

- 1) It is required to charge the battery at least once every 6 months, for this charge maintenance make sure the SOC is charged to higher than 85%.
- 2) Check installation environment such as dust, water, insect etc. Make sure it is suitable for IP20 battery system. Connection of power connector, grounding point, power cable and screw are suggested to be checked every year

### 10.3 Declaration of conformity

The battery system described in this document complies with the applicable European directives. The certificate is available in the download area of our websites.